

# **Systems in Mechanical Engineering 202041**

Mr. K. B. Bansode

# Course Objectives:

---

1. To identify the sources of energy and their conversions
2. To explain the basic concept of engineering thermodynamics and its application
3. To understanding the specifications of vehicles
4. To get acquainted with vehicle systems
5. To introduce manufacturing processes applying proper method to produce components
6. To be able to select and compare domestic appliances



# Course Outcomes

---

On completion of the course, learner will be able to

CO1: Describe and compare the conversion of energy from renewable and non-renewable energy sources

CO2: Explain basic laws of thermodynamics, heat transfer and their applications

CO3: List down the types of road vehicles and their specifications

CO4: Illustrate various basic parts and transmission system of a road vehicle

CO5: Discuss several manufacturing processes and identify the suitable process

CO6: Explain various types of mechanism and its application

# Unit IV Vehicle systems

[https://www.youtube.com/watch?v=r8aWA3eU\\_bs](https://www.youtube.com/watch?v=r8aWA3eU_bs)

Introduction of chassis layouts, steering system, suspension system, braking system, cooling

system and fuel injection system and fuel supply system. Study of Electric and Hybrid Vehicle

systems. Study of power transmission system, clutch, gear box (Simple Numerical), propeller

shaft, universal joint, differential gearbox and axles. Vehicle active and passive safety

arrangements: seat, seat belts, airbags and antilock brake system.



# CHASSIS LAYOUT

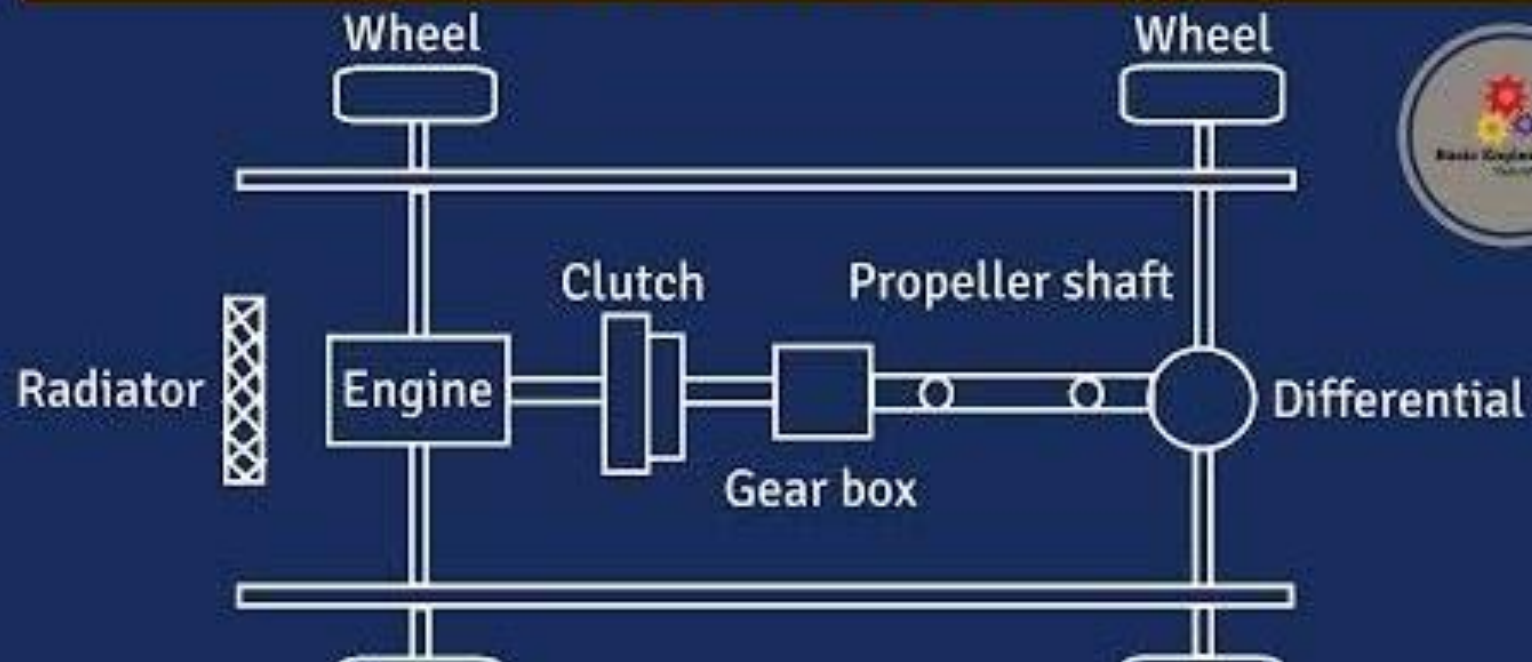

# Ladder Type Chassis Frame Layout

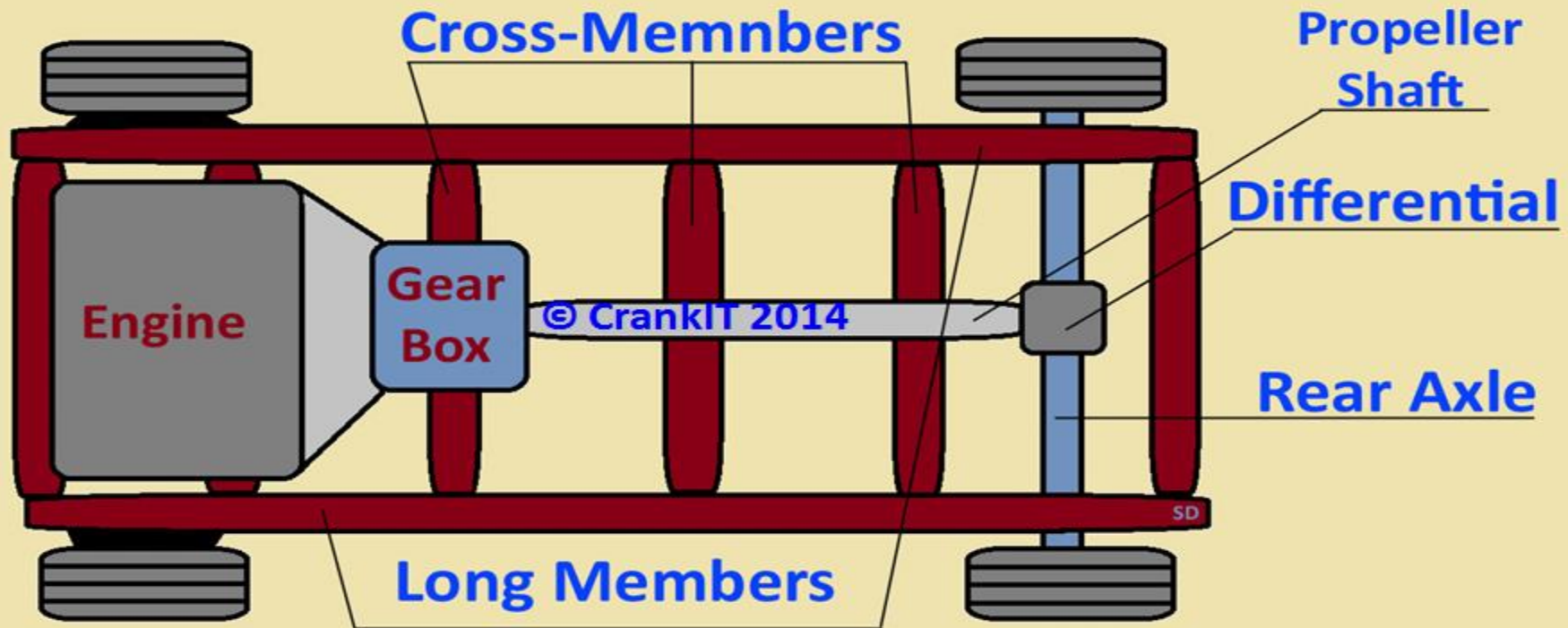

Hosted On [www.crankit.in](http://www.crankit.in)



## ❖ **Steering System:**

- **Steering** is the term applied to the collection of components, linkages, etc. which will allow a vehicle to follow the desired course.
- The front wheels are supported on front axle so that they can swing to left or right for steering. This movement is produced by gearing and linkage between the steering wheel in front of the driver and the steering knuckle or wheel.
- The complete arrangement is called “Steering System”.
- The function of steering system is to convert the rotary movement of the steering wheel into angular turn of the front wheels.
- The steering system also absorb a large part of the road shocks, thus preventing them from being transmitted to the driver.

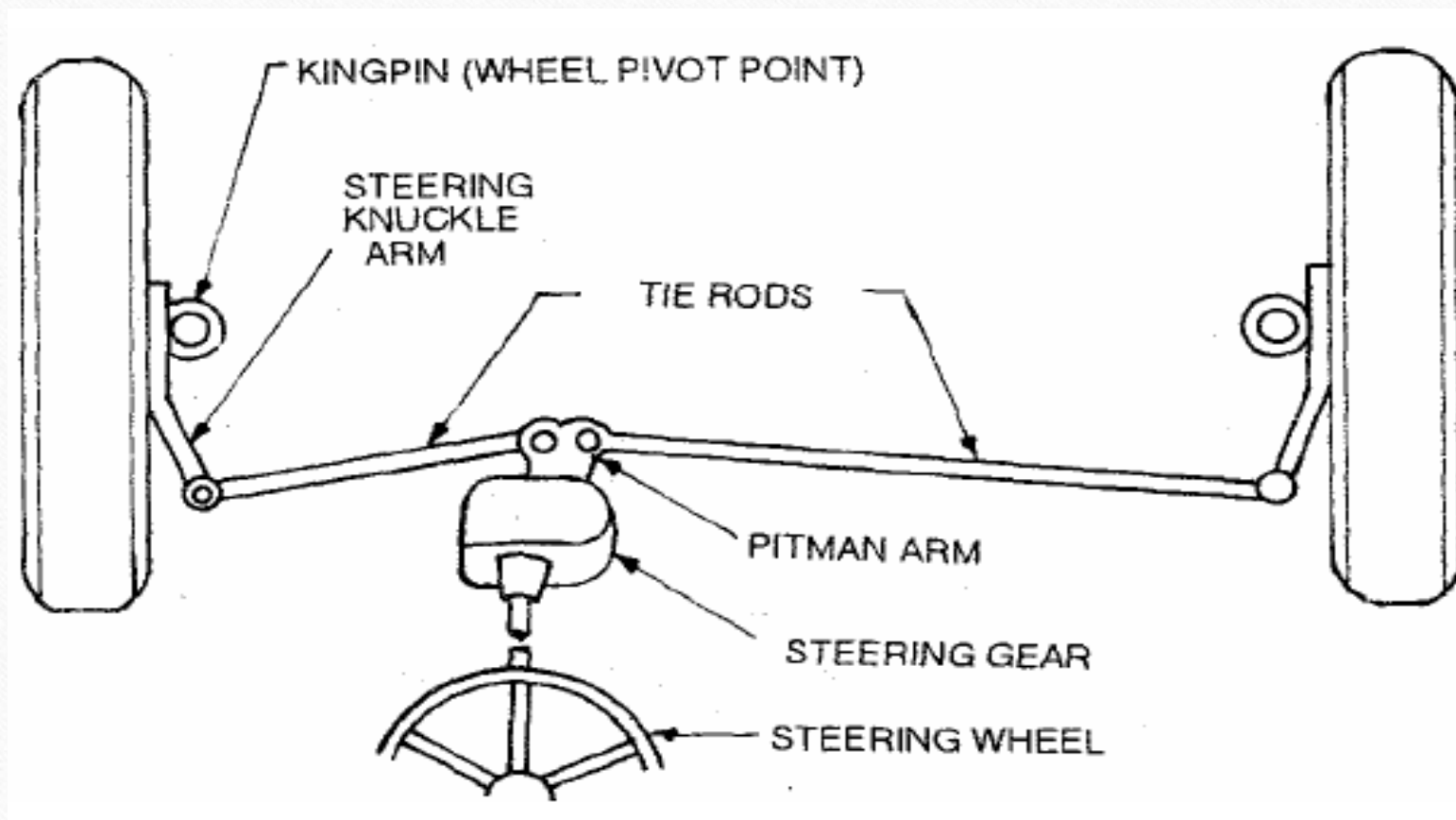



## ❖ Requirements:

- It should multiply the turning effort applied on the steering wheel by the driver.
- It should not transmit the shocks of the road surface encountered by wheels to the driver hands.
- The mechanism should have self-returning property so that when the driver releases the steering wheel after negotiating the turn, the wheel should try to achieve straight ahead position.
- It should be very accurate and easy to handle.

## ❖ **Functions:**

- It helps in swinging or turning the wheels to the left or right (at the will of driver).
- It converts the rotary movement of the steering wheel into an angular turn of the front wheels.
- It multiplies the effort of the driver by leverage in order to make it fairly easy to turn the wheels.
- It absorbs a major part of the road shocks thereby preventing them to get transmitted to the hands of the driver
- It provides directional stability.
- It helps in achieving the self-returning effect.
- Perfect Steering condition.
- Minimize tyre wear.



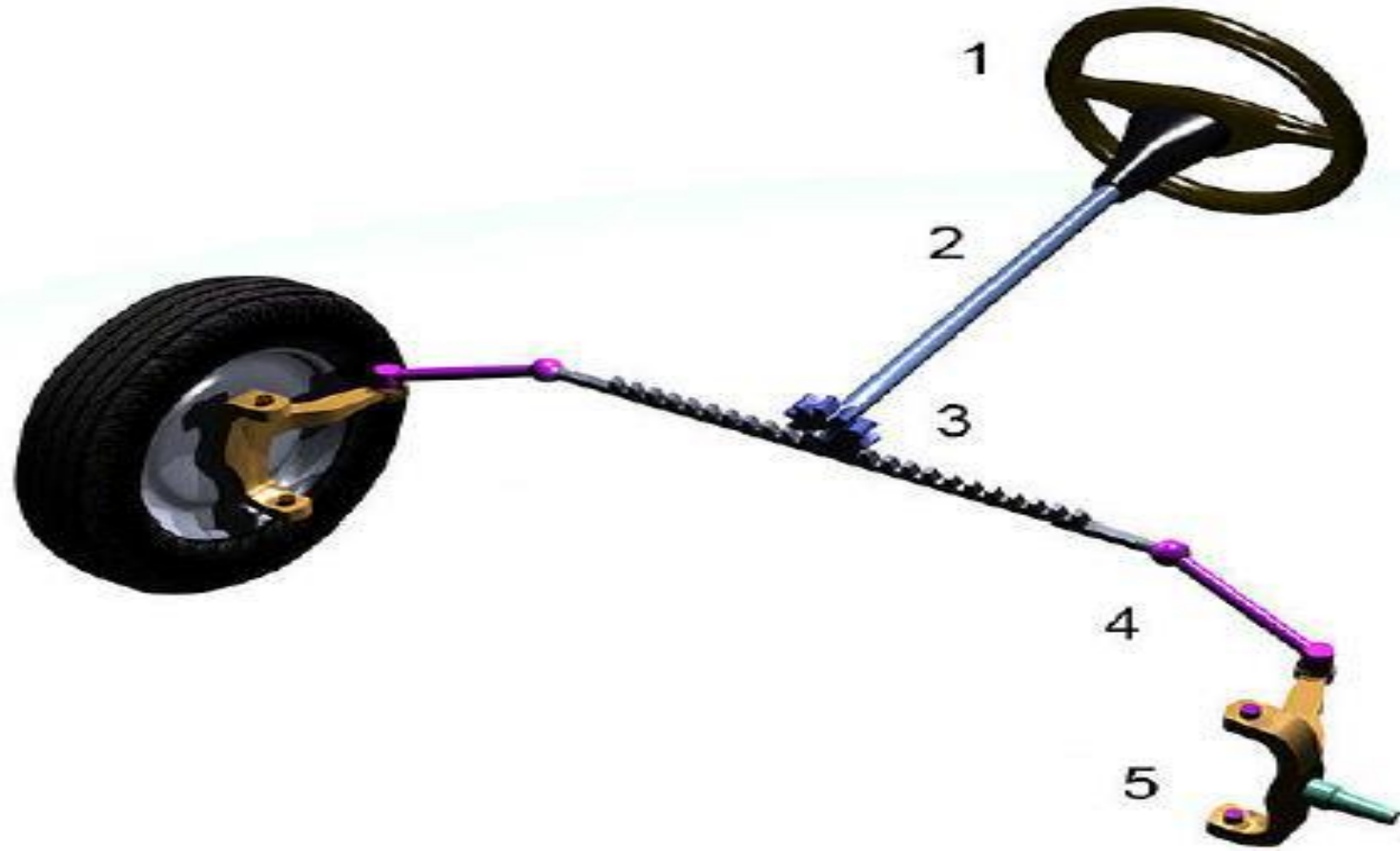

*Rack and pinion steering mechanism: 1 Steering wheel; 2 Steering column; 3 Rack and pinion; 4 Tie rod; 5 Kingpin*

## ❖ **Power Steering:**

- The main objective of power steering is to reduce the driver's effort in steering.
- This system may employ electrical devices and hydraulic pressure.
- Power steering is basically power assisted steering in which an arrangement to boost the steering wheel turning is provided.



- **Hydraulic Power Assisted Steering Gear:**

- When the rack-and-pinion is in a power-steering system, the rack has a slightly different design.
- Part of the rack contains a cylinder with a piston in the middle.
- The piston is connected to the rack. There are two fluid ports, one on either side of the piston.
- Supplying higher-pressure fluid to one side of the piston forces the piston to move which in turn moves the rack so providing power assist.

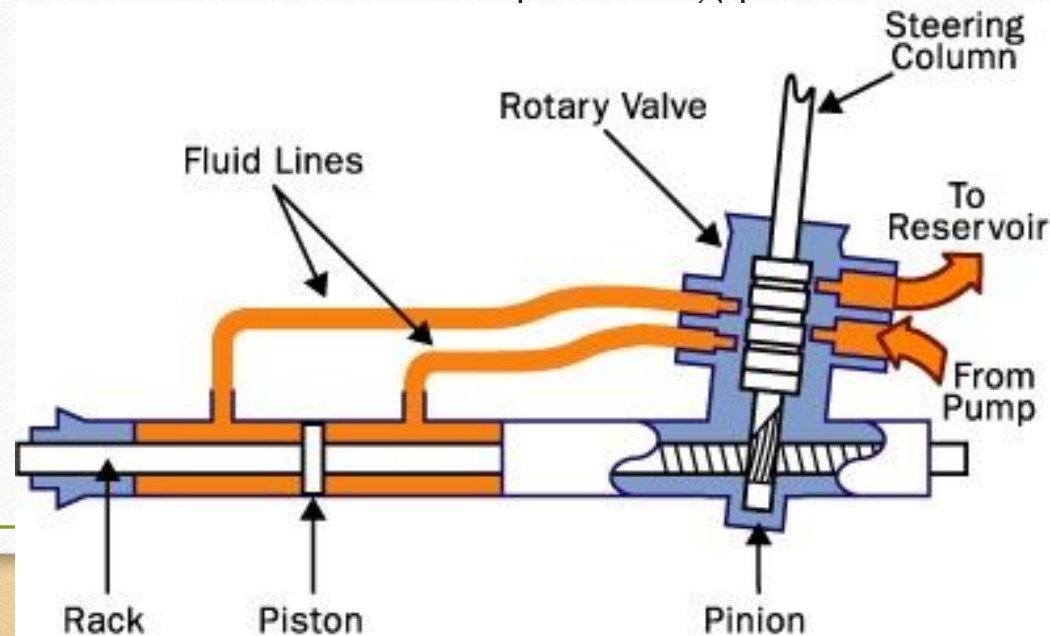

### ❖ Electric Power Assist Steering Gear:

- It uses an electric motor to reduce effort by providing steering assist to the driver of a vehicle.
- Sensors detect the motion and torque of the steering column, and a computer module applies assistive torque via an electric motor coupled directly to either the steering gear or steering column.
- This allows varying amounts of assistance to be applied depending on driving conditions.
- The system allows engineers to tailor steering-gear response to variable-rate and variable-damping suspension systems achieving an ideal blend of ride, handling, and steering for each vehicle.
- In the event of component failure, a mechanical linkage such as a rack and pinion serves as a back-up in a manner similar to that of hydraulic systems.

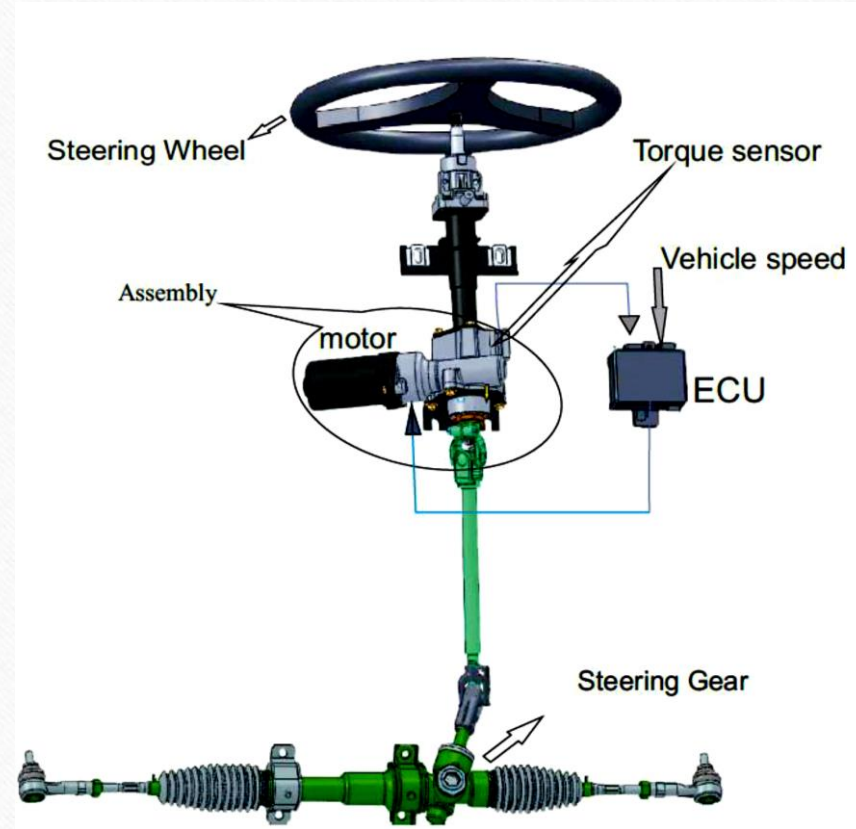



## ❖ Road irregularities:

- The daily use of the road infrastructure, continuous changes of weather conditions, and vehicle's overweight will produce different road surface wearing pattern.
- In addition, deficient road construction process will eventually lead to road surface irregularities.
- Nearly 20% accidents are triggered by infrastructure's condition.
- Potholes, road cracks, unevenness and different friction levels can promote accidents due to emergency maneuvers.



## ❖ Need of Suspension:

1. For absorbing shocks and vibration caused due to road irregularities.
2. For transmitting vehicle load to the wheels (Supporting the weight)
3. For maintaining the stability of vehicle (contact of the wheels to ground)
4. For providing cushioning and ride comfort to the passengers
5. For preventing body squat and body dive.

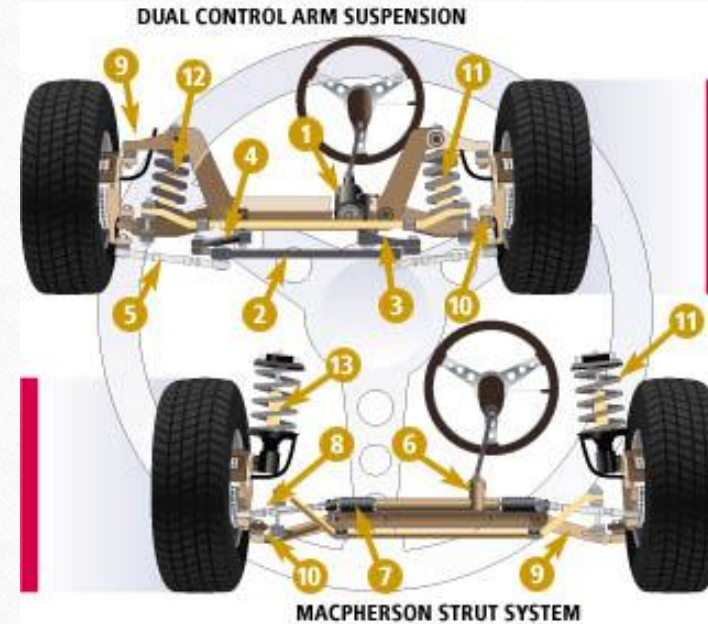



- **Functions:**
  - To safe guard passengers and goods against road shocks
  - To preserve the stability of vehicles while in motion (Pitching or Rolling)
  - To provide the wheels always in contact with road while driving cornering and braking
  - To maintain proper steering geometry
  - To provide suitable riding and cushioning properties
  - To Allow rapid cornering without extreme body roll
  - To prevent excessive **body squat** or **body dive**.

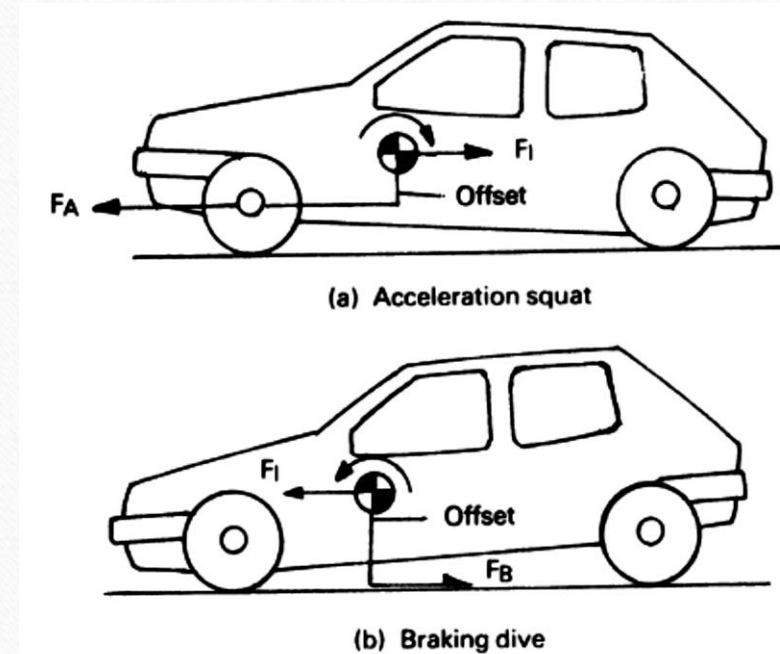

**Fig. 10.61 (a and b)** Vehicle squat and dive

❖ **Requirements:**

1. There should be minimum deflection.
2. It should be of low initial cost.
3. It should be of minimum weight.
4. It should have low maintenance and low operating cost.
5. It should have minimum tyre wear.



## ❖ Vehicle Axis System:

### • Rotations:

- – A roll rotation about x-axis
- – A pitch rotation about y-axis.
- – A yaw rotation about z-axis

### • Basic suspension movements:

1. Bouncing: The vertical movement of the complete body.
- 2. Pitching: The rotating movement of all the parts between the spring and road and the portion of spring weight itself.
- 3. Rolling: The movement about longitudinal axis produced by the centrifugal force during cornering.

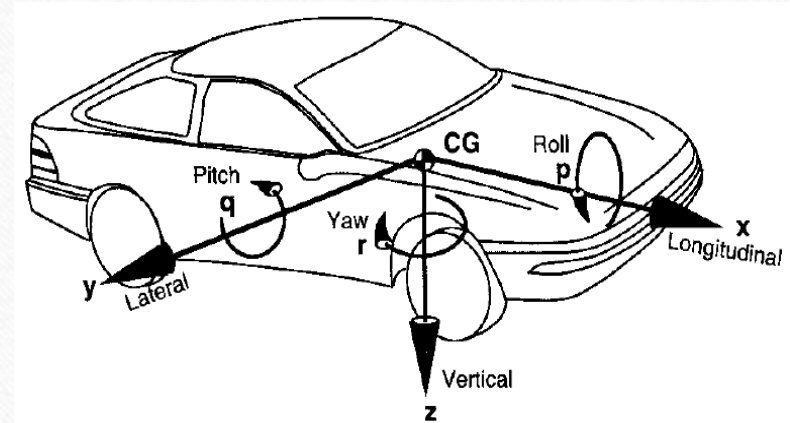

## ❖ Sprung and Un-sprung Masses:-

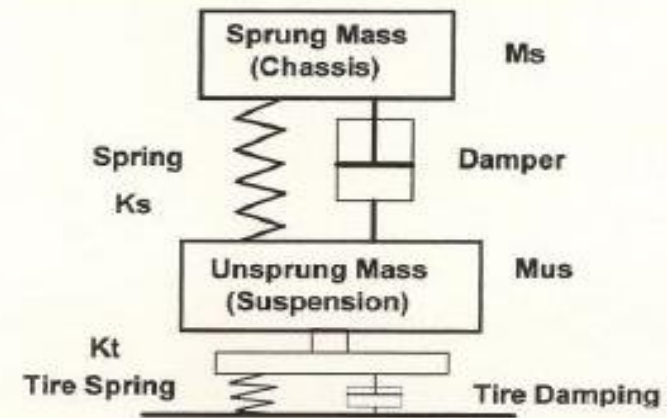
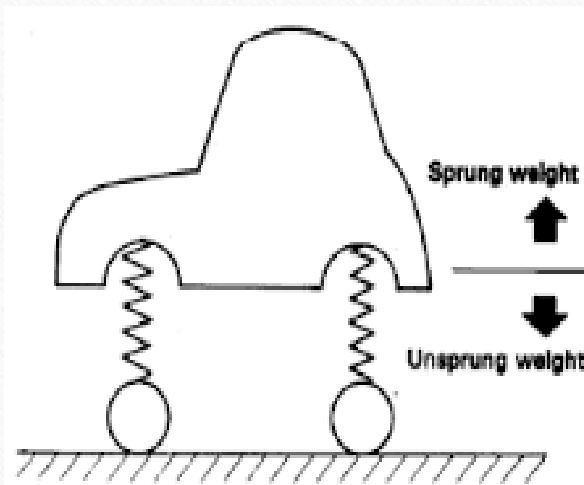



## ❖ Sprung Mass:

- In a vehicle with a suspension, such as an automobile, motorcycle or a tank, sprung mass (or sprung weight) is the portion of the vehicle's total mass that is supported above the suspension.
- The sprung weight typically includes the body, frame, the internal components, passengers, and cargo but does not include the mass of the components suspended below the suspension components (including the wheels, wheel bearings, brake rotors, callipers)

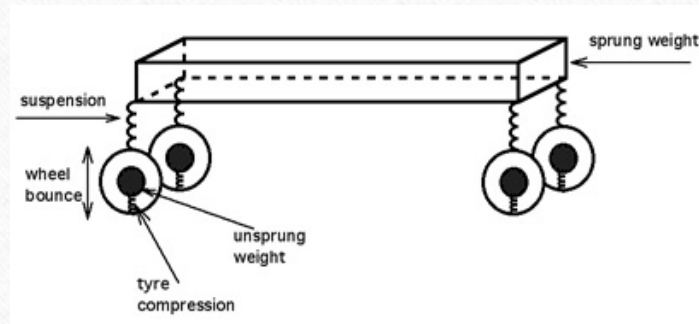

## ❖ Un-sprung Mass:

- In a ground vehicle with a suspension, the un-sprung weight (or the un-sprung mass) is the mass of the suspension, wheels or tracks (as applicable), and other components directly connected to them, rather than supported by the suspension.
- Un-sprung weight includes the mass of components such as the wheel axles, wheel bearings, wheel hubs, tires, and a portion of the weight of drive shafts, springs, shock absorbers, and suspension links.



## ❖ Types of Suspension:

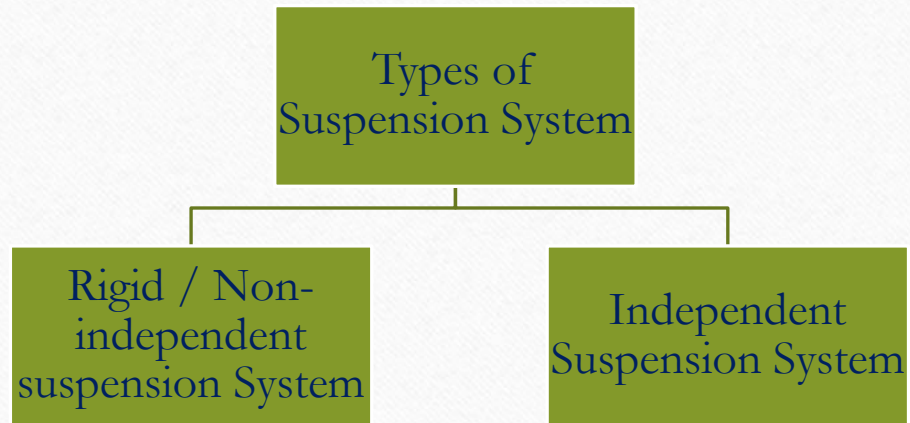

LOW SPEED BUMP WITH THE PATENTED LEHMAN "NO LEAN SUSPENSION"

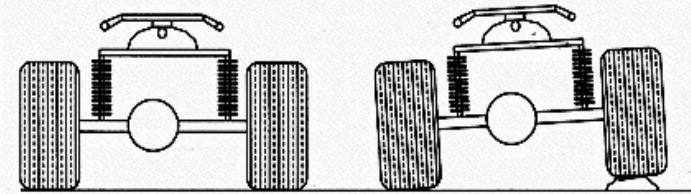

LOW SPEED BUMP WITH INDEPENDENT SUSPENSION

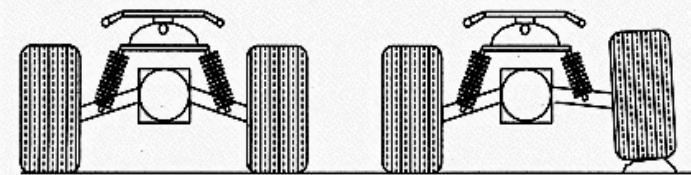

## TYPES OF SUSPENSION SYSTEM

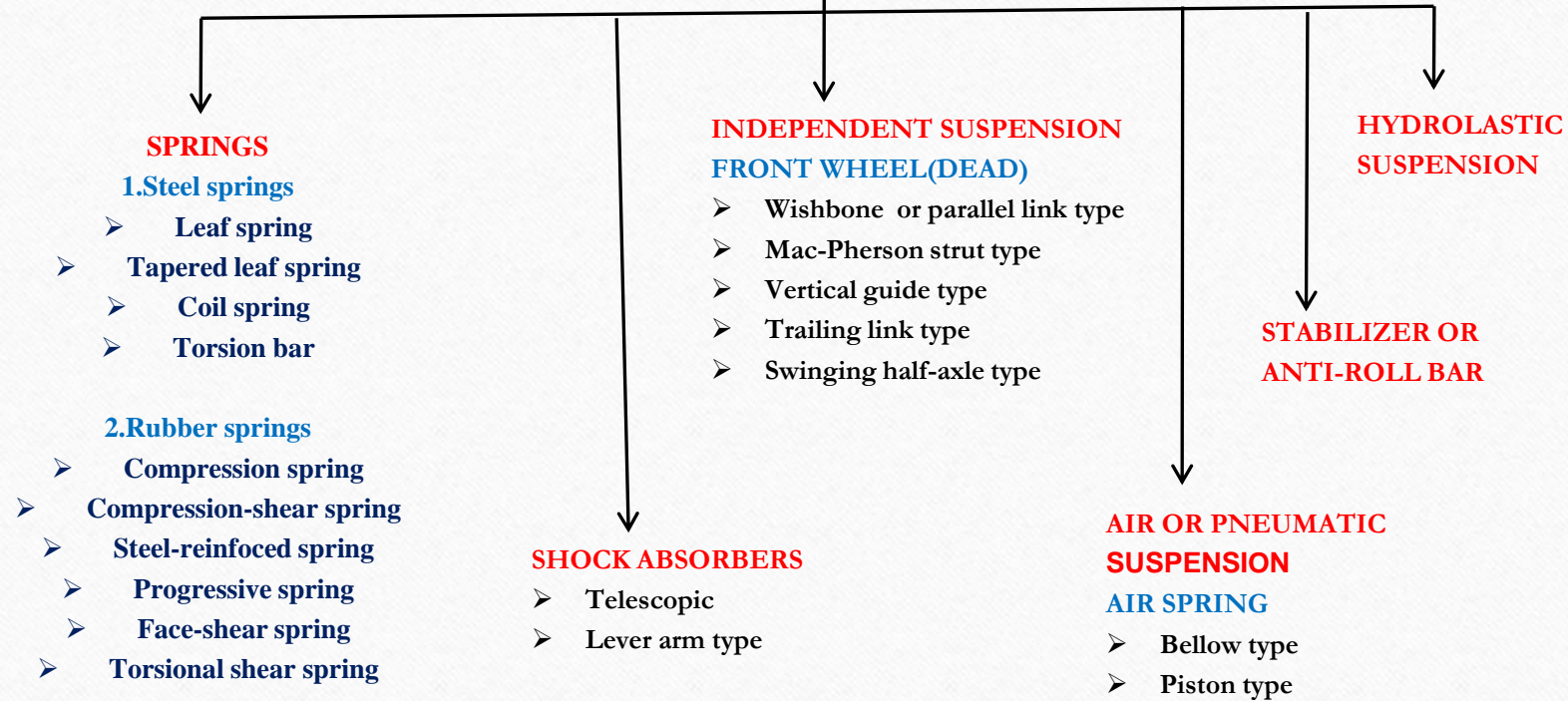



- **1. Non-independent/Rigid suspension** has both right and left wheel attached to the same solid axle. When one wheel hits a bump in the road, its upward movement causes a slight tilt of the other wheel.
- **2. Independent suspension** allows one wheel to move up and down with minimal effect to the other.

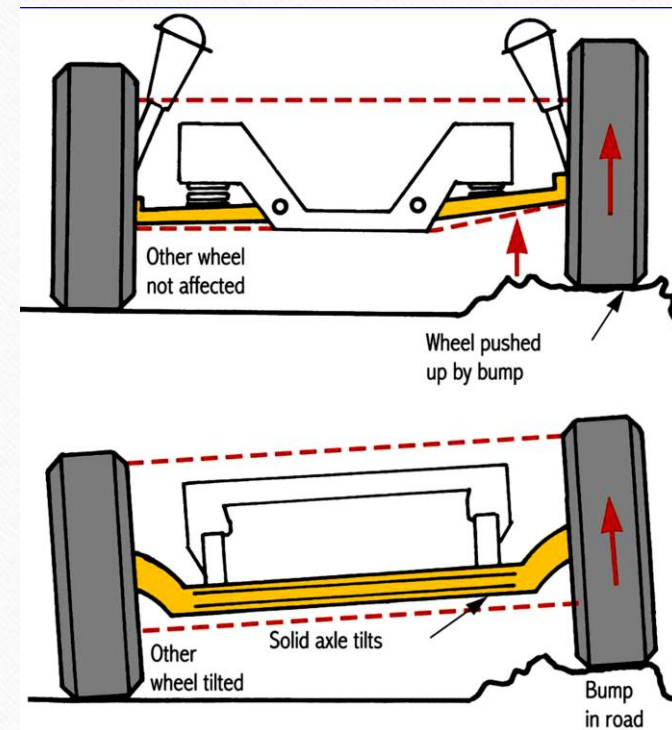

## ❖ **Components of Suspension System:**

- Springs, which neutralize the shocks from the road surface (Energy storage)
- Dampers, which act to improve comfort by limiting the free oscillation of the springs. (Energy Dissipation)
- Stabilizer (sway bar or anti-roll bar), which prevents lateral swaying of the car.
- A linkage system, which acts to hold the above components in place and the control the longitudinal and lateral movements of the wheels.



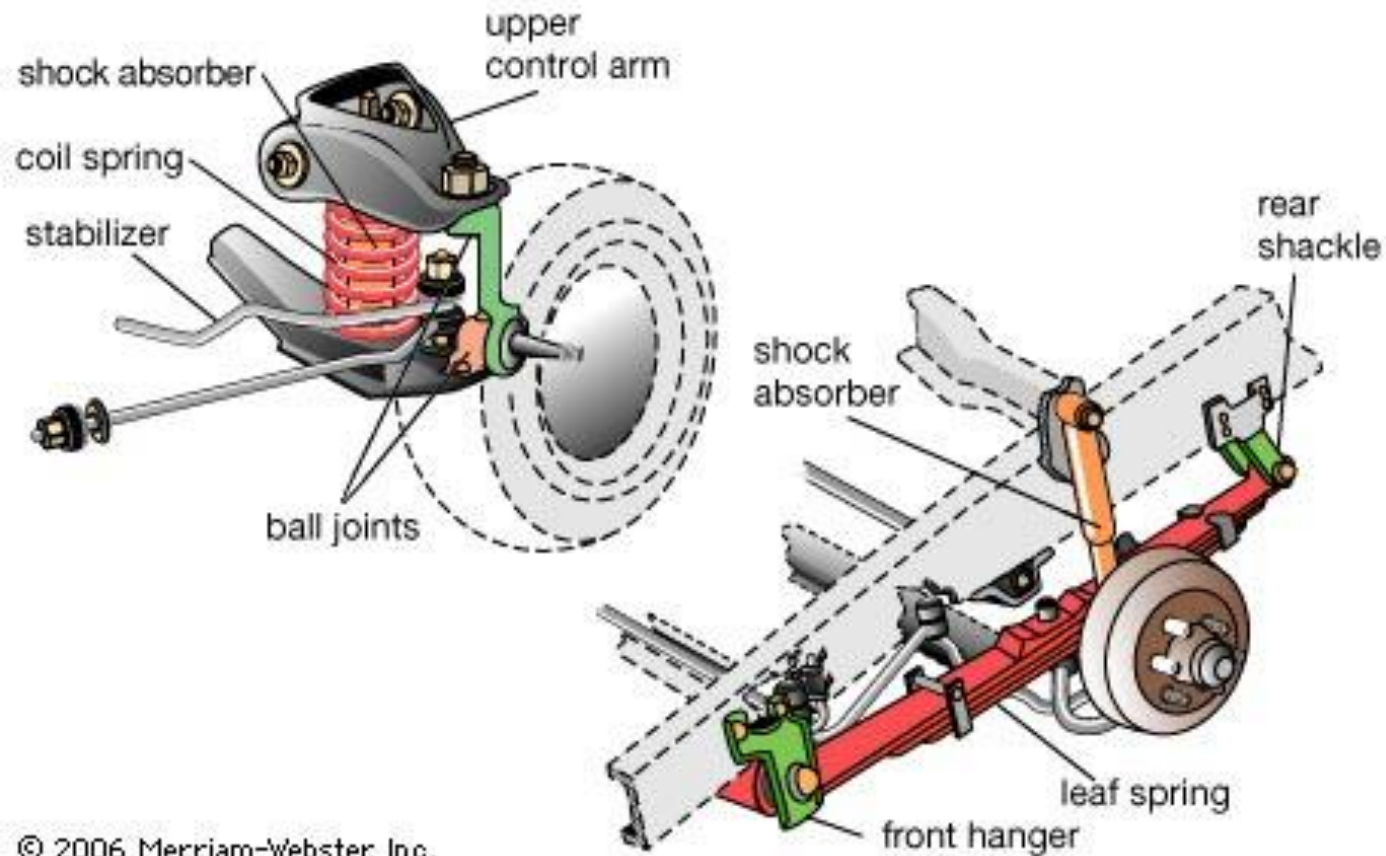

- **Coil spring** is the most common type of spring found on modern vehicles.
- **Leaf springs** are now limited to the rear of some cars.

## ❖ Leaf Springs

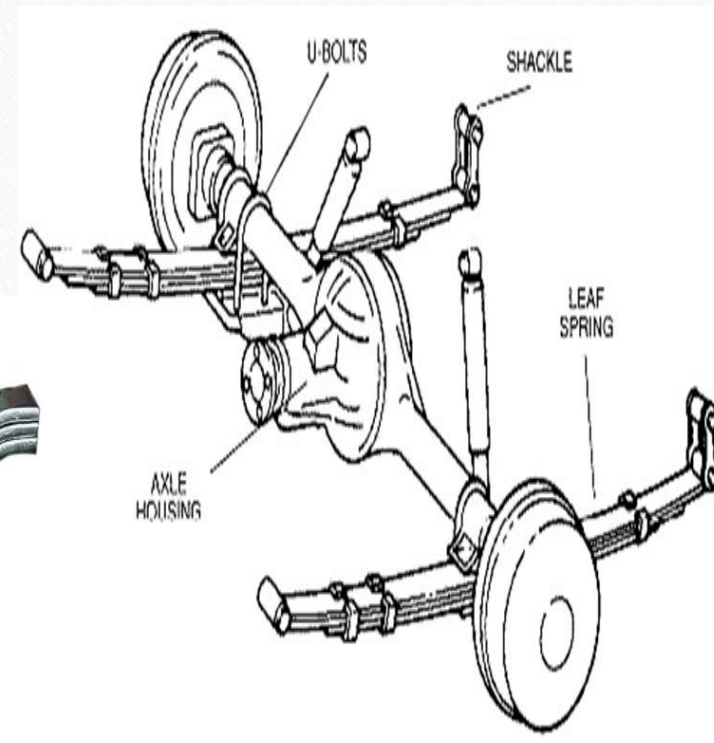
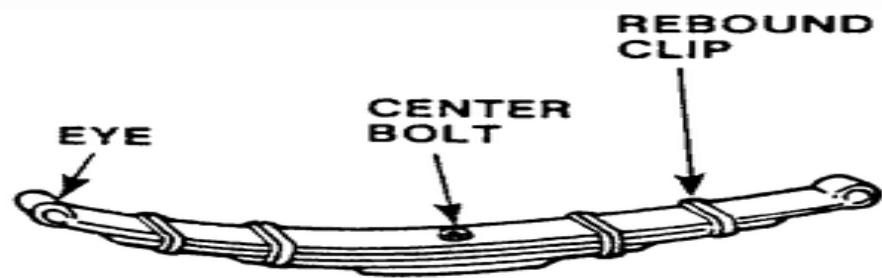



- **Forces and Moments acting on Leaf Spring:**

1. Vertical force caused by vehicle laden weight.
2. Longitudinal forces caused by tractive and braking effort.
3. Transverse forces caused by centrifugal force, side slopes, lateral winds.
4. Rotational torque reaction caused by driving and braking efforts.

## Material Used for Leaf Springs

The suitable steels that have been used for the leaf springs are given below :

### 1. Chrome-vanadium steel

<i>Constituents</i>	<i>Percentage</i>
C	0.46
Mn	0.57
Si	0.17
Ni	0.15
Cr	1.40
Va	0.18

### 2. Silico-Manganese Steel

<i>Constituents</i>	<i>Percentage</i>
C	0.52
Mn	1.05
Si	1.95
Cr	0.05

### 3. Carbon Steel

<i>Constituents</i>	<i>Percentage</i>
C	0.55
Mn	0.60
Si	0.20



## ❖ Leaf Spring

- Leaf spring was invented by Obadiah Elliot of London in 18<sup>th</sup> century. He simply piled one steel plate on top of another, pinned them together and shackled each end to a carriage, it was the first ever leaf spring used on a vehicle.
- It is originally called as a laminated or carriage spring, and sometimes referred to as a semi-elliptical spring or cart spring.

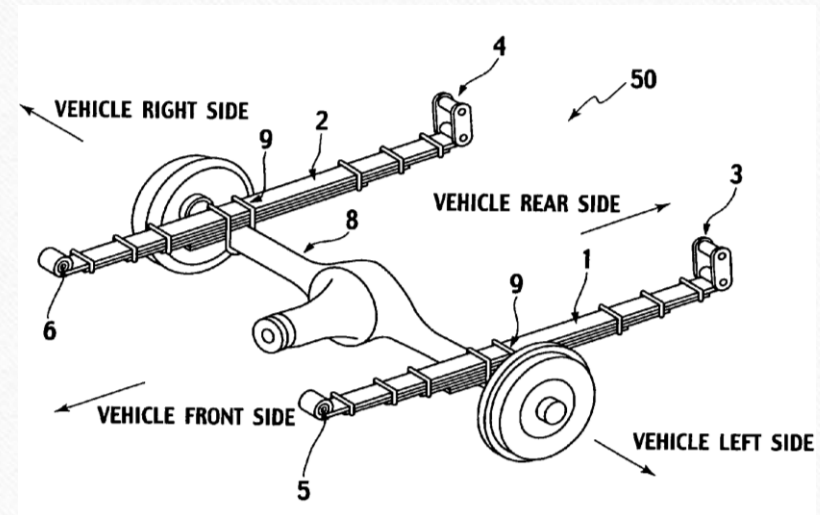

## ❖ Leaf Springs:

- Leaf springs are formed by bending.
- They are made of long strips of steel.
- Each strip is named as Leaf.
- The long leaf is called Master Leaf, and it consists of eyes at its both ends.
- One end is fixed to the chassis frame, the other end is fixed to the shackle spring.
- The spring will get elongated during expansion and shortened during compression.
- This change in length of spring is compensated by the shackle.
- The U-bolt and clamps are located at the intermediate position of the spring.
- The bronze or rubber bushes are provided on both eyes on the master leaf.

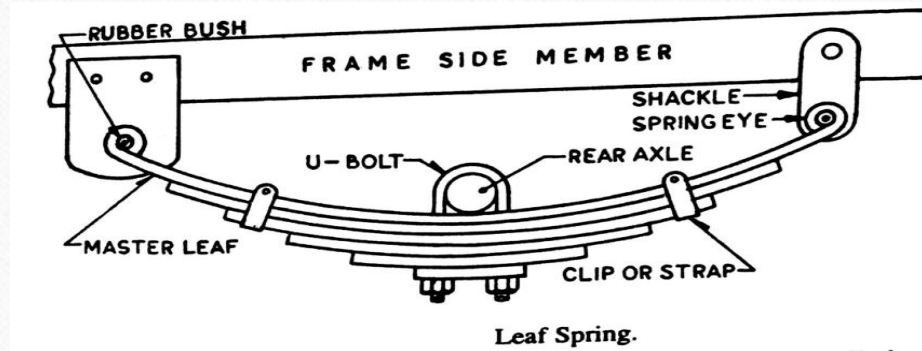







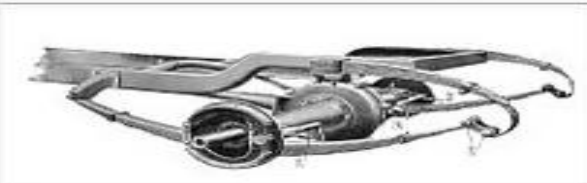
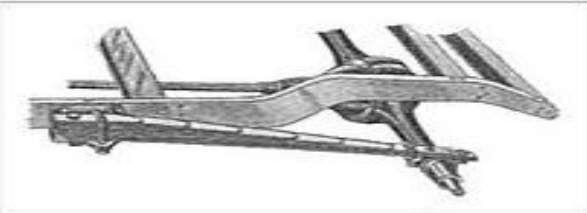

## ❖ Types:

- There are six types of leaf springs
  1. Full – elliptic type
  2. Semi – elliptic type
  3. Quarter – elliptic type
  4. Three Quarter – elliptic type
  5. Transverse Spring type
  6. Helper Spring type

Elliptic	
Semi-elliptic	
Three quarter-elliptic	
Quarter-elliptic	
Transverse	



## 1. Full – elliptic

- The advantage of this type is the elimination of shackle and spring.
- The lubrication and wear frequently which are on of the main draw back of this type of springs

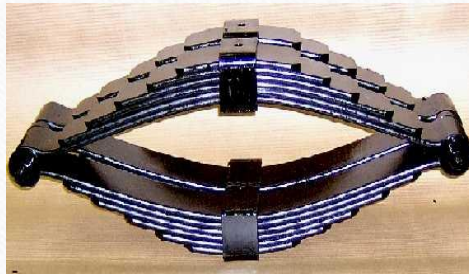

- **2. Semi – elliptic**

- Mostly used in Trucks, buses (for rear and front Suspension) and in some cars (for rear suspension)

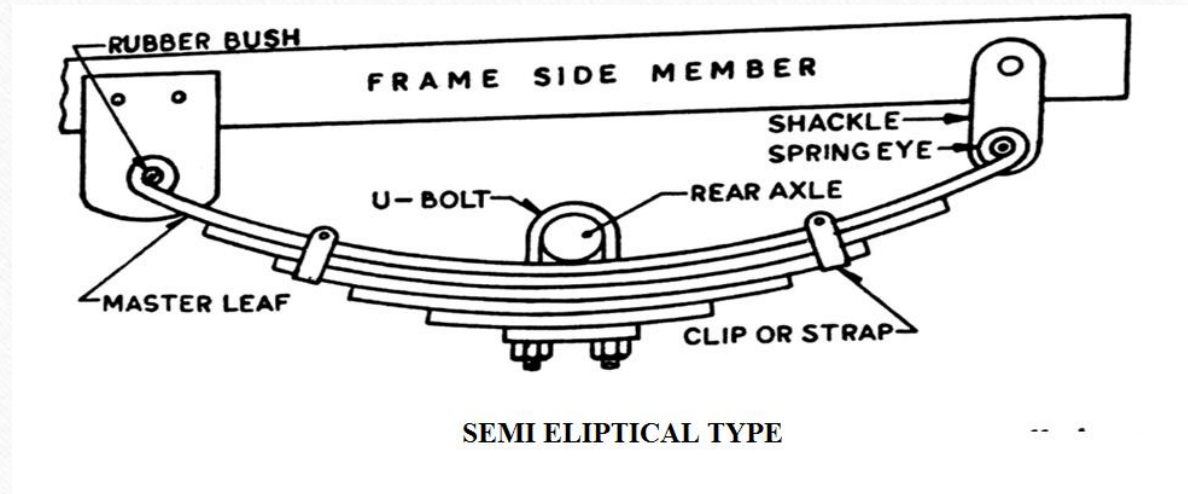



- 3. Quarter – elliptic
- This type is rarely used in now-a-days.
- It gives very less resistance in road shocks.

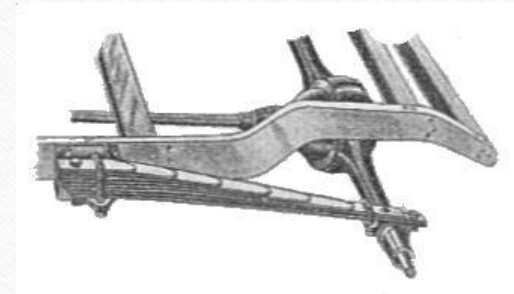
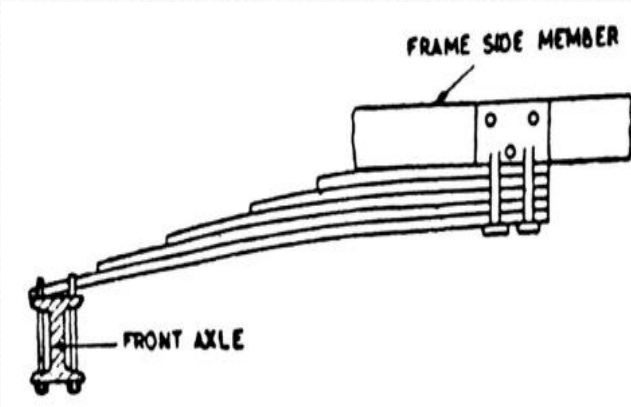

#### 4. Three Quarter – elliptic

This type is rarely used in now-a-days.

It gives good resistance to shocks, but occupies more space than other types.

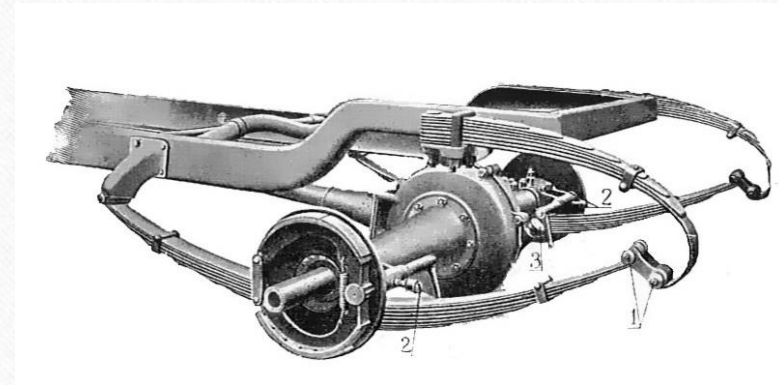
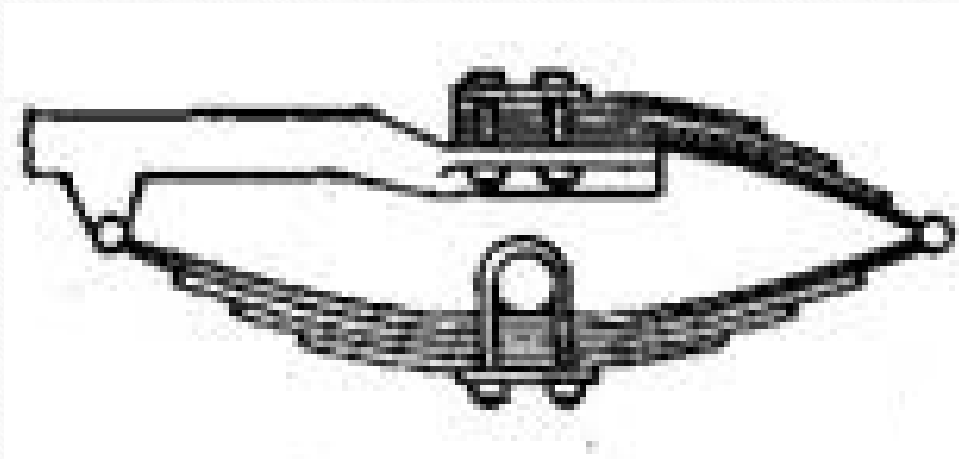



- **5. Transverse Spring**

- This type of spring is arranged transversely across the vehicle instead of longitudinal direction.
- The transverse spring for front axle, which is bolted rigidly to the frame at the centre and attached to the axle by means of shackle at both ends.
- Disadvantage of this spring is that the vehicle body in this case is attached to the springs at only two places, which imparts the vehicle a tendency to roll easily when it runs fast on sharp corners.

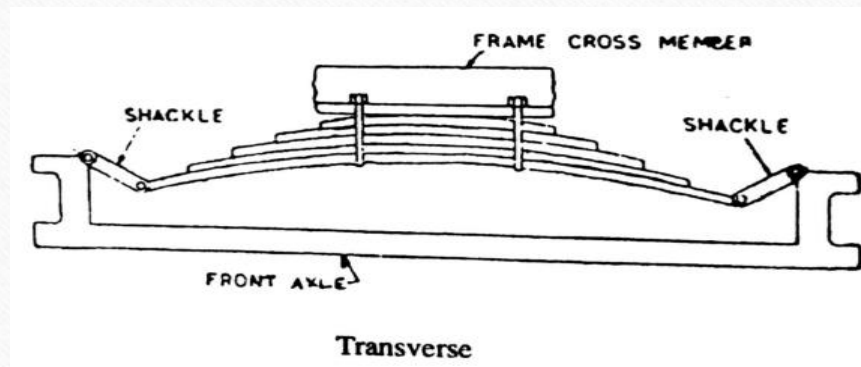

- **6. Helper Spring**

- Helper spring are provided on many commercial vehicles in addition to the main leaf springs.
- They allow wide range of loading. When the vehicle is lightly loaded, these helper springs do not come into operation.
- But as load is increased, they take their share of load.
- Generally helper springs are used on rear suspension.

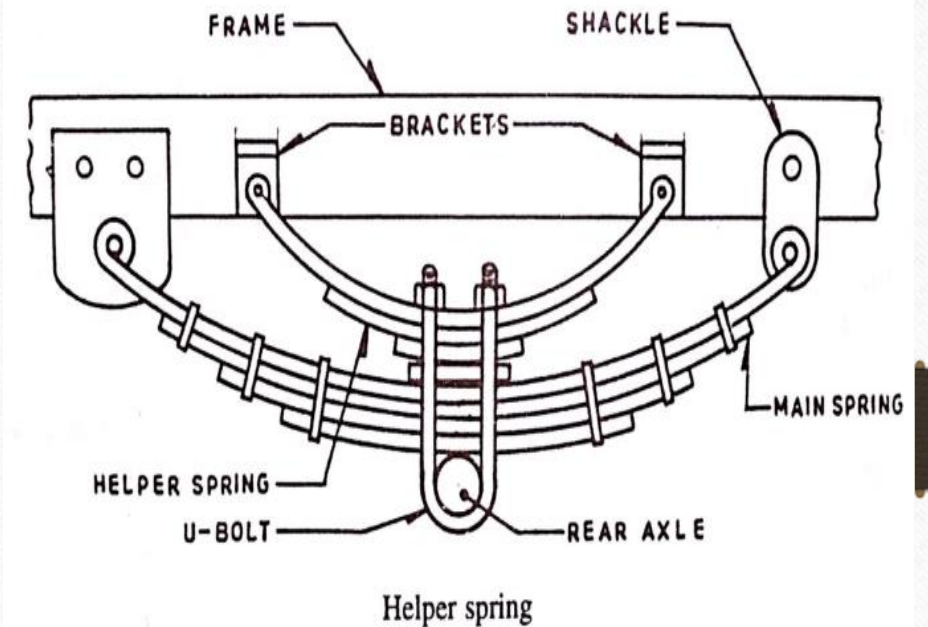



## Taperlite Spring

English Steel Corporation Ltd. of England has produced 'Taperlite' springs, which have the following advantages over the conventional leaf springs due to which these are becoming increasingly popular compared to constant-section conventional leaf springs.

1. Light weight—Nearly 60% of the corresponding conventional spring.
2. There is no interleaf friction in case of single taper leaf spring.
3. Absence of squeaking.
4. The stresses are lower and more uniform compared to the conventional springs, thus giving longer life.
5. They occupy less space.
6. In case of single taper leaf spring, there is no collection of moisture between the leaves



**Taperlite spring**

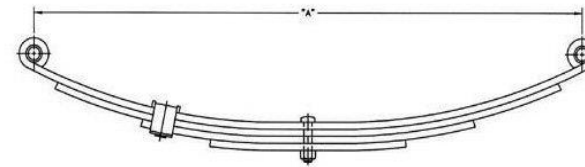
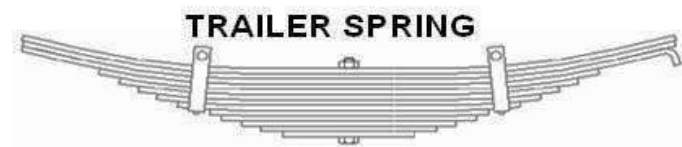
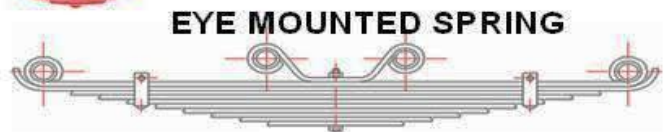
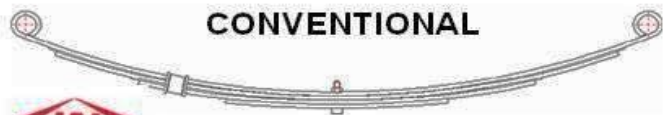

Measure Mounting Point To Mounting Point Center

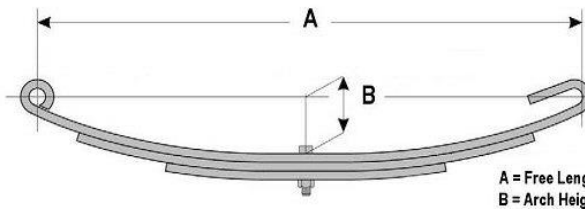

Measure Mounting Point to Furthest Inside Point

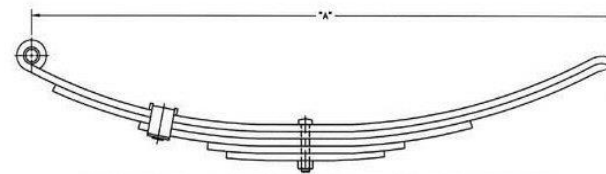

Measure Front Bolt To End Of Spring



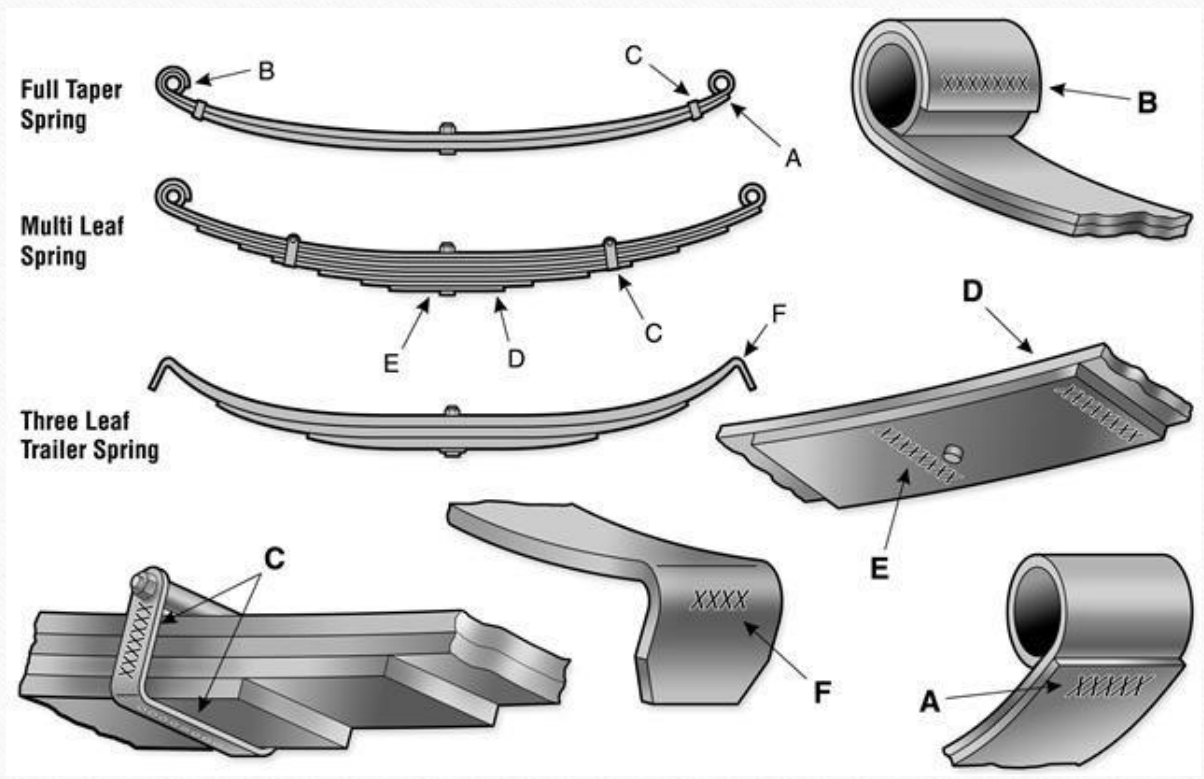

Heavy truck springs for Mercedes,  
Isuzu, Scania, Man, Mack, Bedford, etc



Small trailer springs for box type trailers,  
boat trailers, agricultural trailers, horse floats  
and classic cars.

4WD springs for Jeep, Toyota Land Cruiser,  
Ford, GM, Chevy, of different lifts



Semi-trailer springs for BPW, Rubery Owen,  
Fruehauf, Frighter Hendirckson, etc.



## ❖ Manufacturing Process

1. Shearing of flat bar
2. Center hole punching / Drilling
3. End heating process forming
  - - Eye Forming / Wrapper Forming
  - - Diamond cutting / end trimming / width cutting / end tapering
  - - End punching / end grooving / end bending / end forging / eye grinding
  - - Center hole punching / Drilling / nibbing
4. Heat Treatment
  - - Heating
  - - Chamber forming
  - - Hardening
  - - Quenching
  - - Tempering

- 5. Surface preparation
  - - Shot peening / Stress peening
  - - Primary painting
- 6. Eye bush preparation process
  - - Eye reaming / eye boring
  - - Bush insertion
  - - Bush reaming
- 7. Assemble
  - - Presetting & load testing
  - - Finish painting
  - - Marking & packing



## ❖ Characteristics of Leaf Spring

- Leaf spring acts as a linkage for holding the axle in position and thus separate linkage are not necessary. It makes the construction of the suspension simple and strong.
- As the positioning of the axle is carried out by the leaf springs so it makes it disadvantageous to use soft springs i.e. a spring with low spring constant.
- Therefore, this type of suspension does not provide good riding comfort.
- The inter-leaf friction between the leaf springs affects the riding comfort.
- Acceleration and braking torque cause wind-up and vibration. Also wind-up causes rear-end squat and nose-diving.

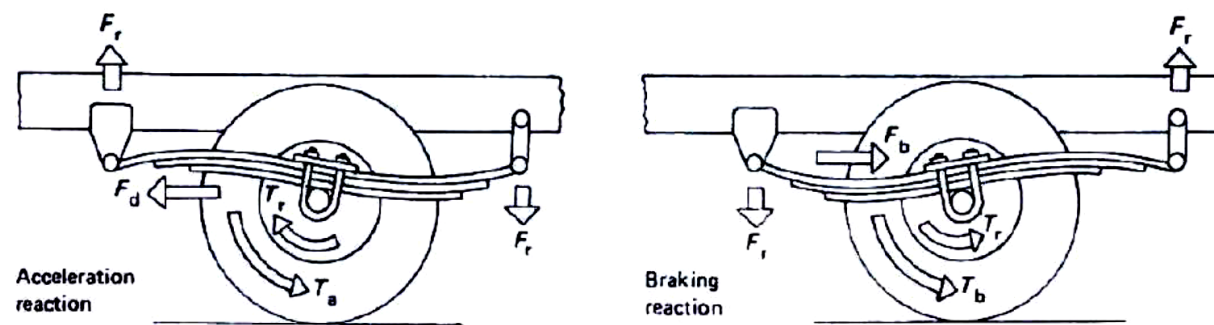

Acceleration and braking reaction forces acting on the spring shackles

$F_d$  – Driving force,     $F_r$  – Reaction force,     $F_b$  – Braking force,  
 $T_r$  – Reaction Torque,     $T_b$  – Braking torque,     $T_a$  – Acceleration Torque

## ❖ Coil Springs:

- Coil springs are made of special round spring steel wrapped in a helix shape.
- The strength and handling characteristics of a coil spring depend on the following.
  1. Coil diameter
  2. Number of coils
  3. Height of spring
  4. Diameter of the steel coil that forms the spring
- The larger the diameter of the steel, the “stiffer” the spring.
- The shorter the height of the spring, the stiffer the spring.
- The fewer the coils, the stiffer the spring.

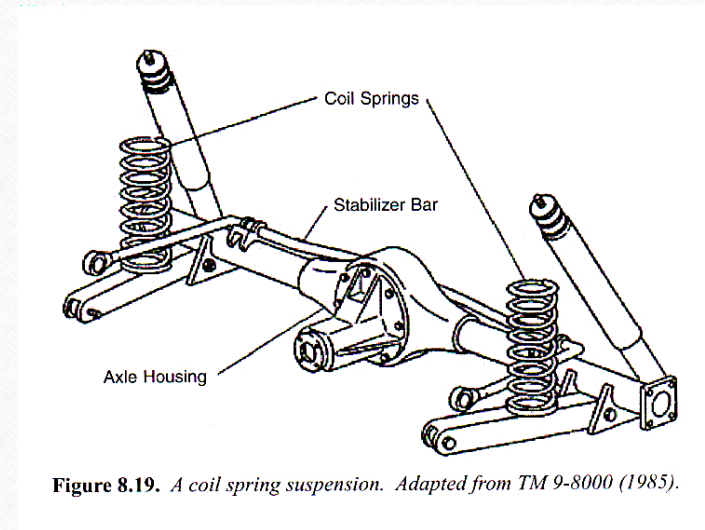
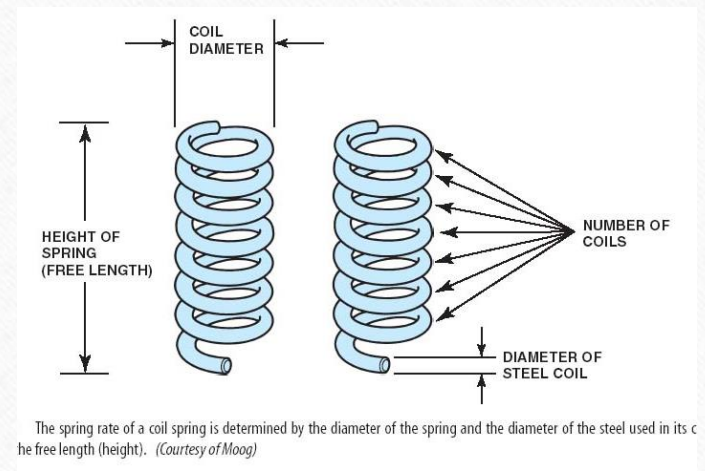

Figure 8.19. A coil spring suspension. Adapted from TM 9-8000 (1985).





- The coil springs are used mainly with independent suspension, though they have also been used in the conventional rigid axle suspension as they can be well accommodated in restricted spaces.
- The energy stored per unit volume is almost double in the case of coil springs than the leaf springs.
- Coil springs do not have noise problems nor do they have static friction
- Coil springs can take the shear as well as bending stresses.
- The coil springs however cannot take torque reaction and side thrust for which alternative arrangements have to be provided.
- A helper coil spring is also sometimes used to provide progressive stiffness against increasing load.

Springs are designed to provide desired ride and handling and come in a variety of spring ends.

### COIL SPRING ENDS

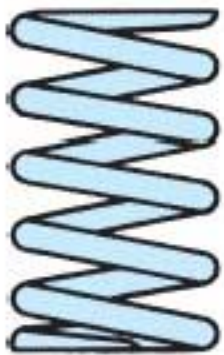

TAPERED  
END

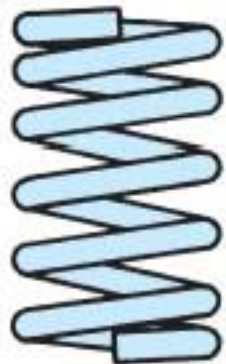

TANGENTIAL  
END



PIG -  
TAIL

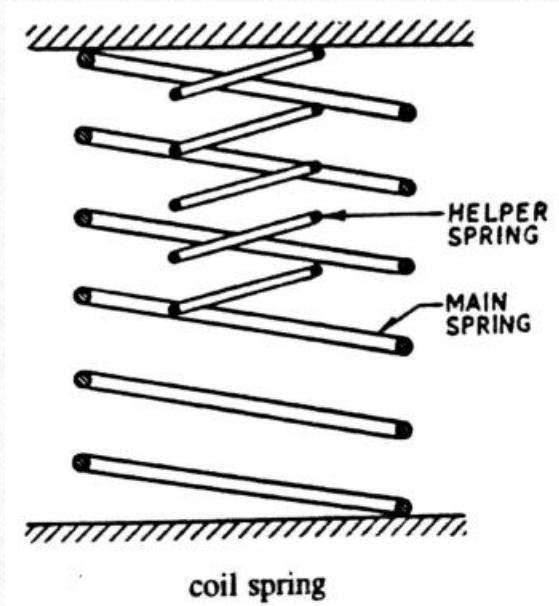

**FIGURE 5-10** Coil spring ends are shaped to fit the needs of a variety of suspension designs.



## ❖ Spring Rate

- **Spring rate**, also called **deflection rate**, is a value that reflects how much weight it takes to compress a spring a certain amount.
- The spring rate (or stiffness or spring constant) is defined as the load required per unit deflection of the spring. Mathematically

$$k = W / \delta$$

$W$  = Load, and

$\delta$  = Deflection of the spring.

- A **constant-rate spring** continues to compress at the same rate throughout its complete range of deflection.
- A **variable-rate spring** may compress one inch under a 100-pound load, but only compress an additional half an inch under a 200-pound load.

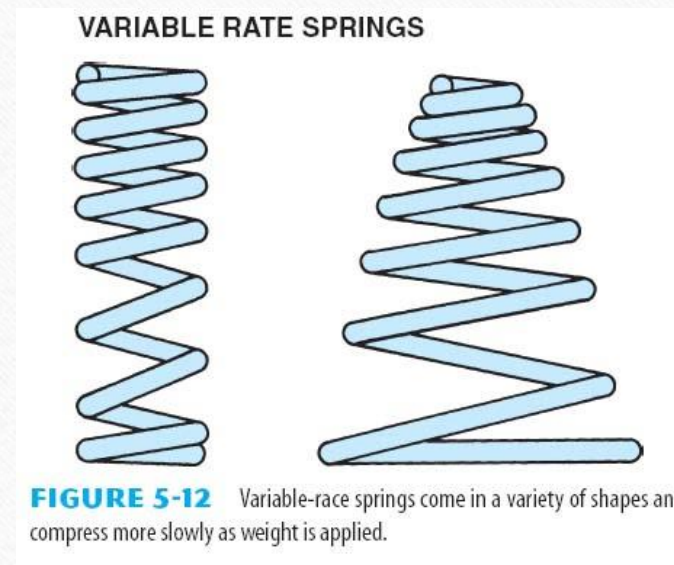
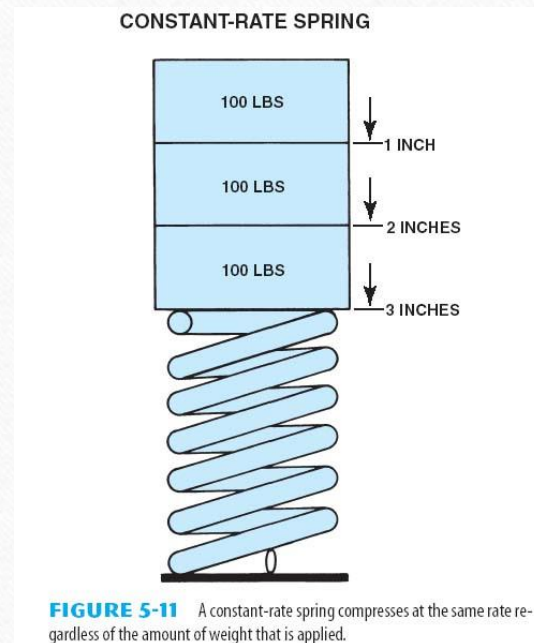



Before a spring is installed on a vehicle or any load is placed on it, it is at its **uncompressed length**, or free length. Once installed, the weight of the corner of the vehicle resting on the spring is called its **static load**.

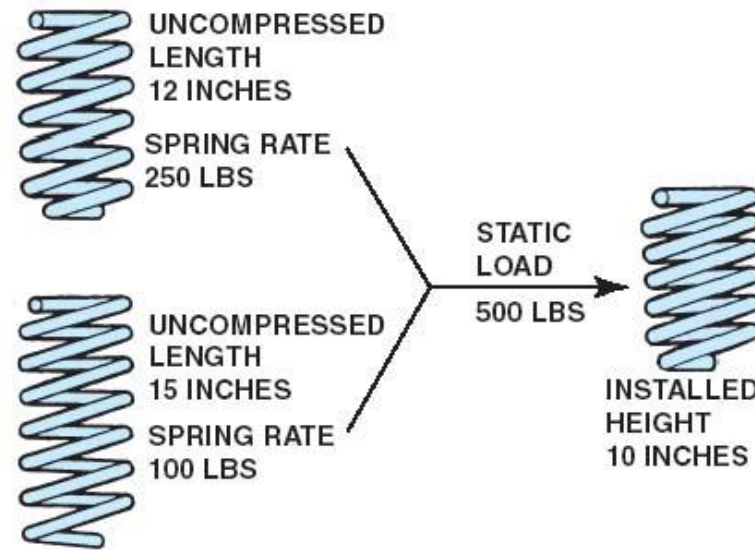

**FIGURE 5-13** Two springs, each with a different spring rate and length, can provide the same ride height even though the higher-rate spring will give a stiffer ride.

## ❖ Coil Spring Mounting

- Coil springs are usually installed in a **spring pocket** or **spring seat**. Hard rubber or plastic **cushions** or **insulators** are usually mounted between the coil spring and the spring seat.

## ❖ Spring Coatings

- All springs are painted or coated with epoxy to help prevent breakage. A scratch, nick or pit caused by corrosion can cause a **stress riser** that can lead to spring failure.

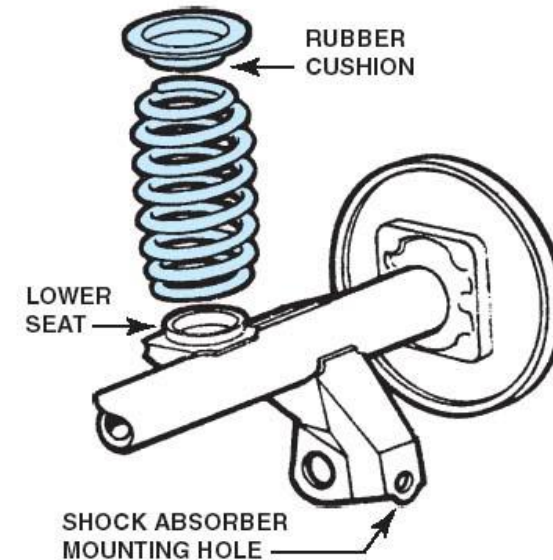

**FIGURE 5-16** The spring cushion helps isolate noise and vibration from being transferred to the passenger compartment. (Courtesy of Moog)



## ❖ Rubber Springs

- As rubber can store more energy per unit mass than any other type of spring material, considerable weight can be saved with rubber suspension.
- It is more compact than other springs.
- It has also excellent vibration damping property.
- One more advantage of using rubber is that it is not suddenly fail like steel so there is less risk.
- First introduced in 1958 by Eric Moulton.



❖ Working:

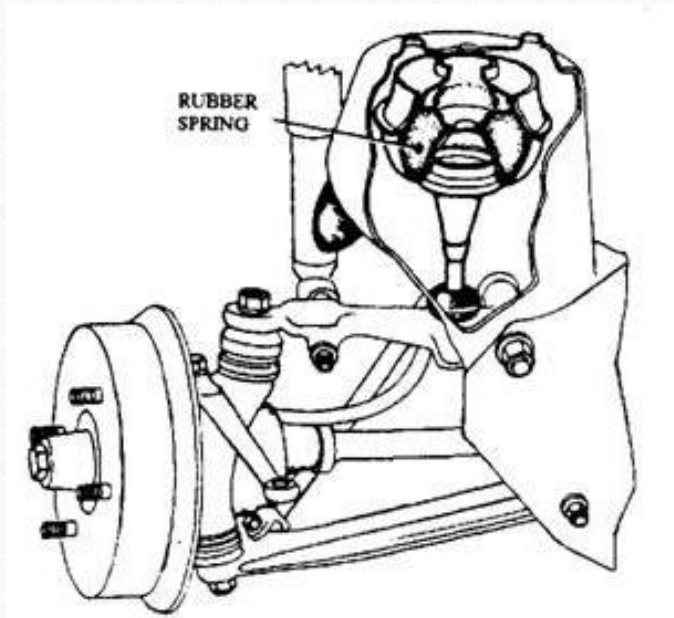
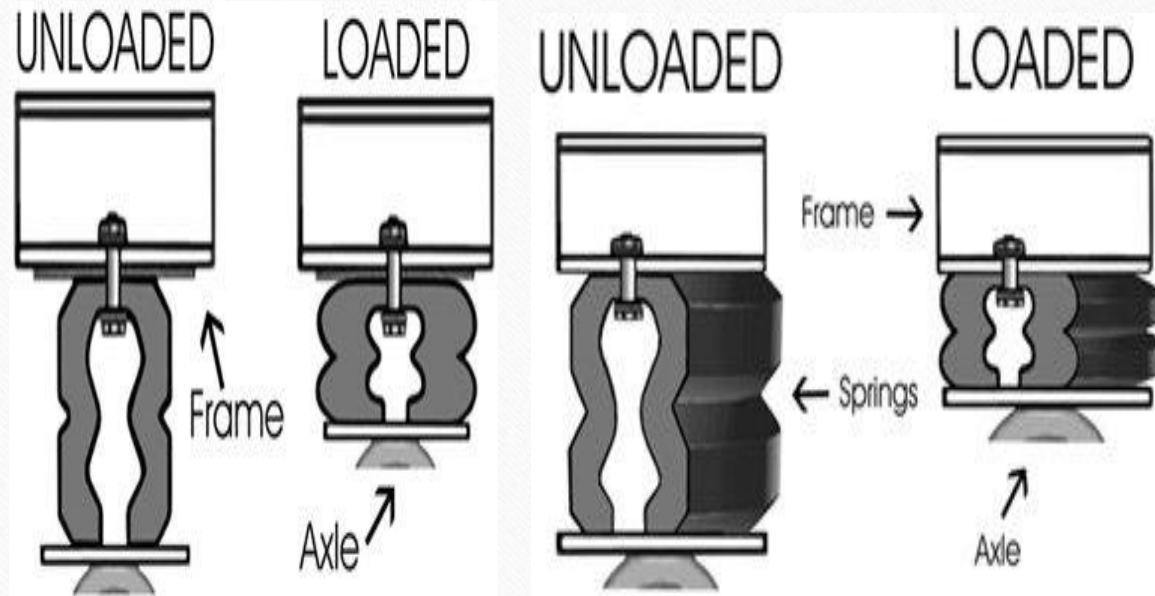



- Fig. represents a rubber suspension system in a simplified form, that is similar to the one used on a popular small car.
- The spring is installed between the frame and the top link of the suspension system.
- When the spring is connected to a point near the link pivot, deflection of the spring reduces to a minimum, without affecting the total wheel movement.
- This arrangement of spring provides a rising-rate characteristic, which is 'soft' for small wheel movements but becomes harder as the spring deflects.
- The energy released from the rubber spring after deflection is considerably less than that imparted to it.
- This internal loss of energy is called hysteresis, which is an advantage, because lower-duty dampers may be used.
- Some rubber suspension systems have a tendency to 'settle down' or 'creep' during the initial stages of service, therefore allowance for this must be provided

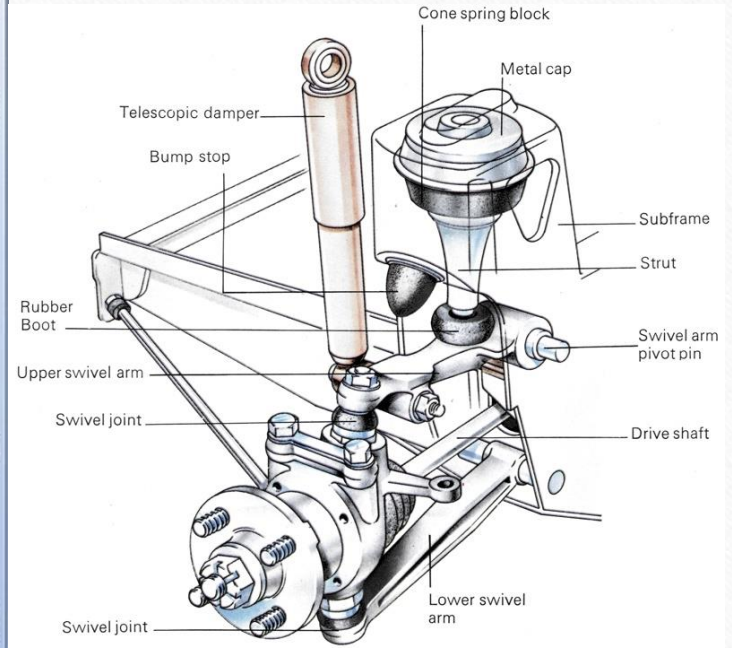
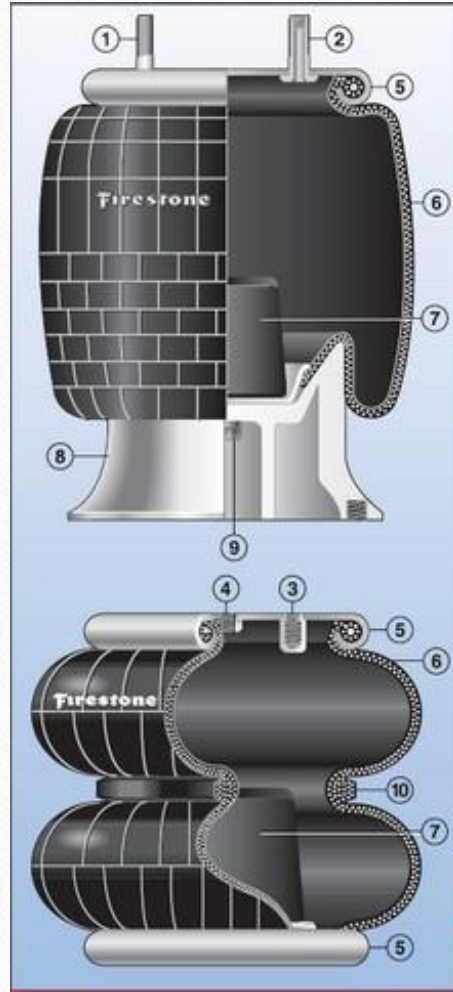



❖ Types:

1. Compression spring
2. Compression-shear spring
3. Steel-reinforced spring



## 1. Compression Spring

- This type of spring is still being used because of following advantages,
  - It is reliable, of simple construction and requires no bonding.
  - It provides a rising rate characteristics.
  - It can resist occasional overload of large magnitude.
  - It has a large measure of damping than most types of rubber springs.
- However, its use is limited because of the fact that some mechanical guide must be provided with this type of spring and the provision of mechanical guide generally undesirable.

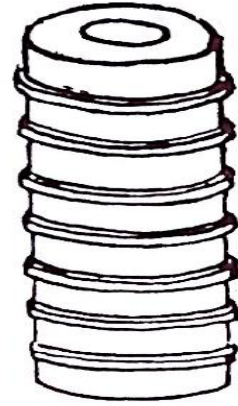

**Compression spring.**





- **2. Compression-Shear Spring**

- In this type, the load is carried partly by shear and by compression components in the rubber.

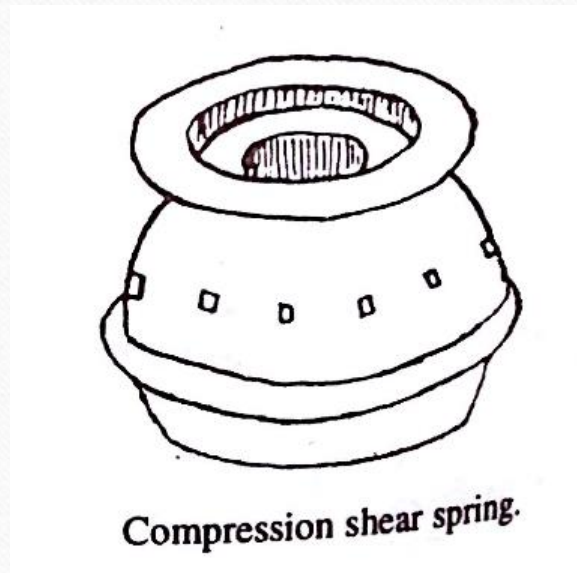

- **3. Steel-reinforced spring**

- Steel reinforced spring (Eligos Spring) consist of a steel helical spring bonded in rubber body.
- The steel spring though carrying only about 20% of the load, exercises a stabilizing influence on the rubber component thereby allowing a greater stroke/diameter ratio to be used without other forms of guiding



**Steel reinforced spring.**





## ❖ Torsion Bars:

- This is a straight bar of circular or square section fixed to the frame at one end, and a lever or wishbone-shaped member connects its other end to the wheel. A torsion bar suspension system used on a car is illustrated in Fig.
- The diameter is increased at each end of the bar and the bar is connected with the levers by serrations. Provision for the adjustment is made at the frame end to 'level' the suspension.
- Since the coil spring is a form of torsion bar, the rate of both springs depends on the length and diameter. The rate decreases or the spring becomes softer if the length is increased or the diameter is decreased.

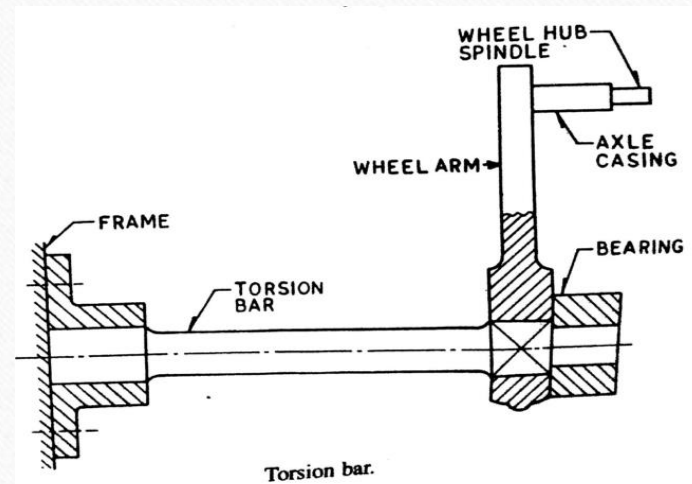
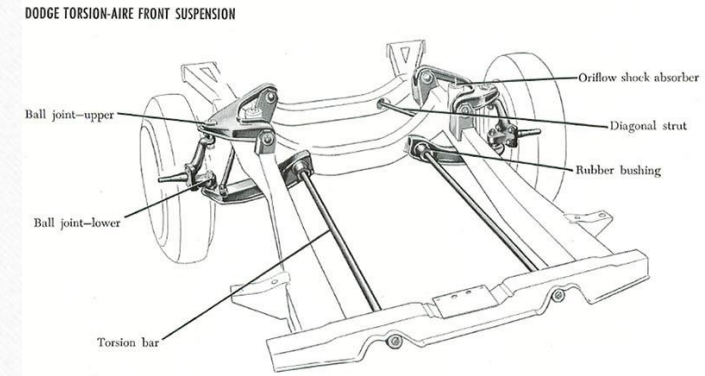

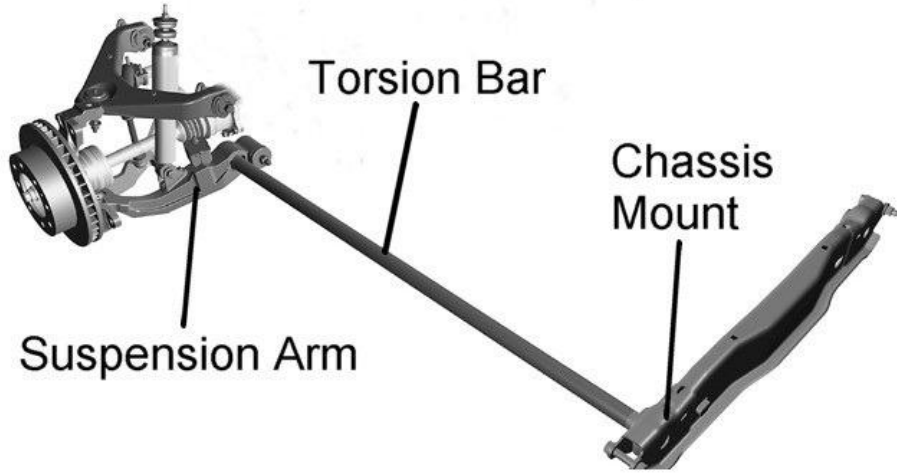
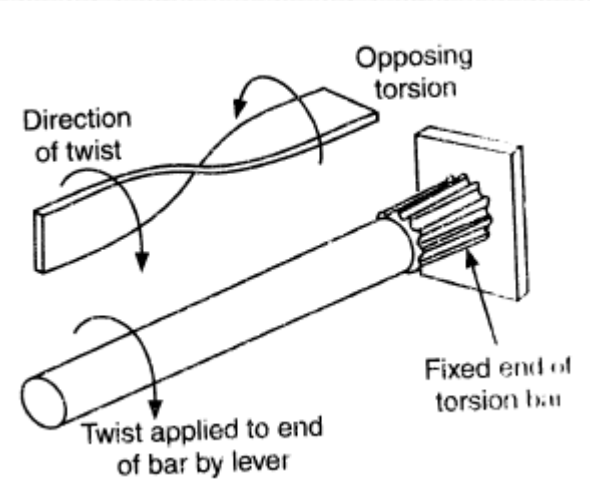
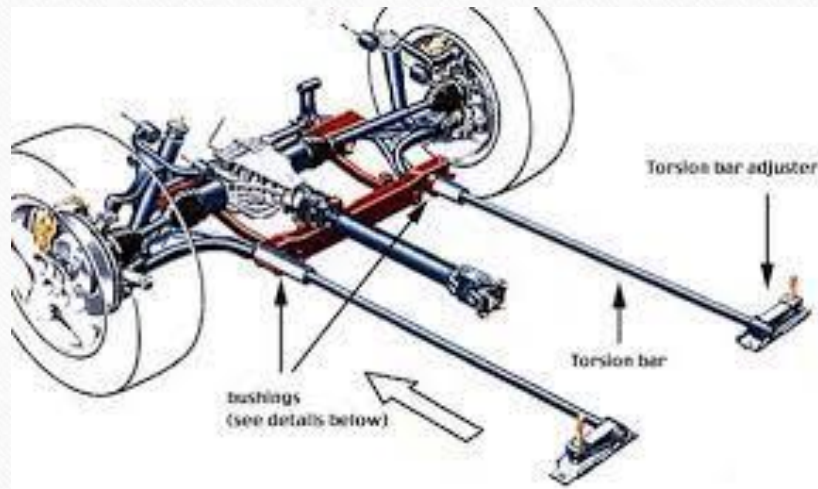

**COMPONENTS OF TORSION BAR**

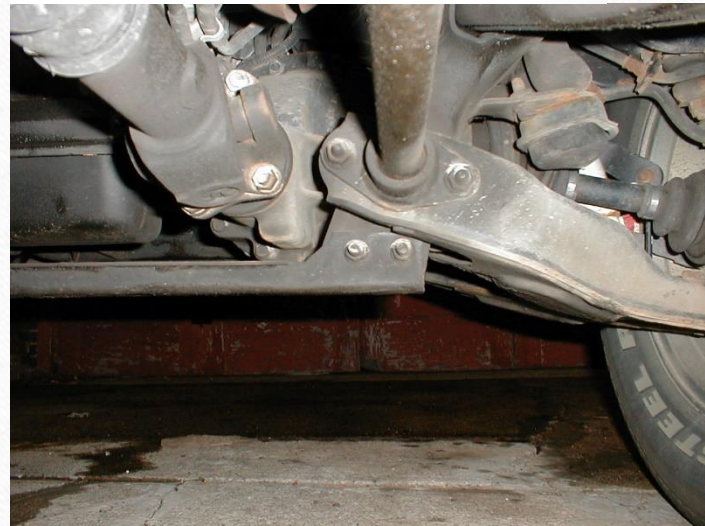



- **Advantages**

- Light in weight.
- Less space required.
- Its maintenance cost is less.
- Initial cost is less.
- Ride comfort is more.

- **Disadvantages**

- It does not take acceleration & Braking thrust so required additional linkages
- Lack of friction damping

❖ Air Suspension:





# Engine Cooling & Car Radiator History

- Heat dissipation is probably one of the most important considerations in engine design.
- An internal combustion engine creates enough heat to destroy itself.
- Without an efficient cooling system, we would not have the vehicles we do today.
- The original radiators were simple networks of round copper or brass tubes that had water flowing through them by convection.
- By the 1920's some auto manufacturers, like GM, had switched to oval tubes because they were slightly more efficient.
- Not long after that, as engines grew larger and hotter, companies began to add fans for a constant flow of air over the radiator cores.
- These more efficient cooling systems eventually added a pump to push the water through the cooling tubes.
- All in all, the car radiator is a simple and lasting technology that will likely be around as long as we use internal combustion engines.

# Engine Cylinder Cooling Systems

- There are mainly two types of cooling systems :
- (a) Air cooled system, and
- (b) Water cooled system.



# Air Cooled System

- Air cooled system is generally used in small engines say up to 15-20 kW and in aero plane engines.
- In this system fins or extended surfaces are provided on the cylinder walls, cylinder head, etc.
- Heat generated due to combustion in the engine cylinder will be conducted to the fins and when the air flows over the fins, heat will be dissipated to air.
- The amount of heat dissipated to air depends upon :
  - (a) Amount of air flowing through the fins.
  - (b) Fin surface area.
  - (c) Thermal conductivity of metal used for fins

# Finned Engine Cylinder

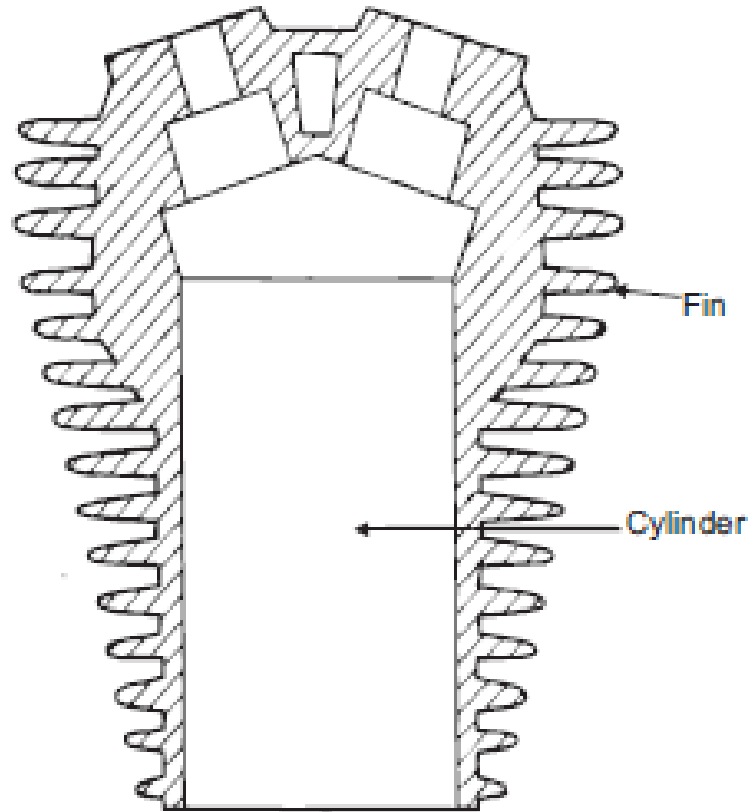



# Liquid Cooling System

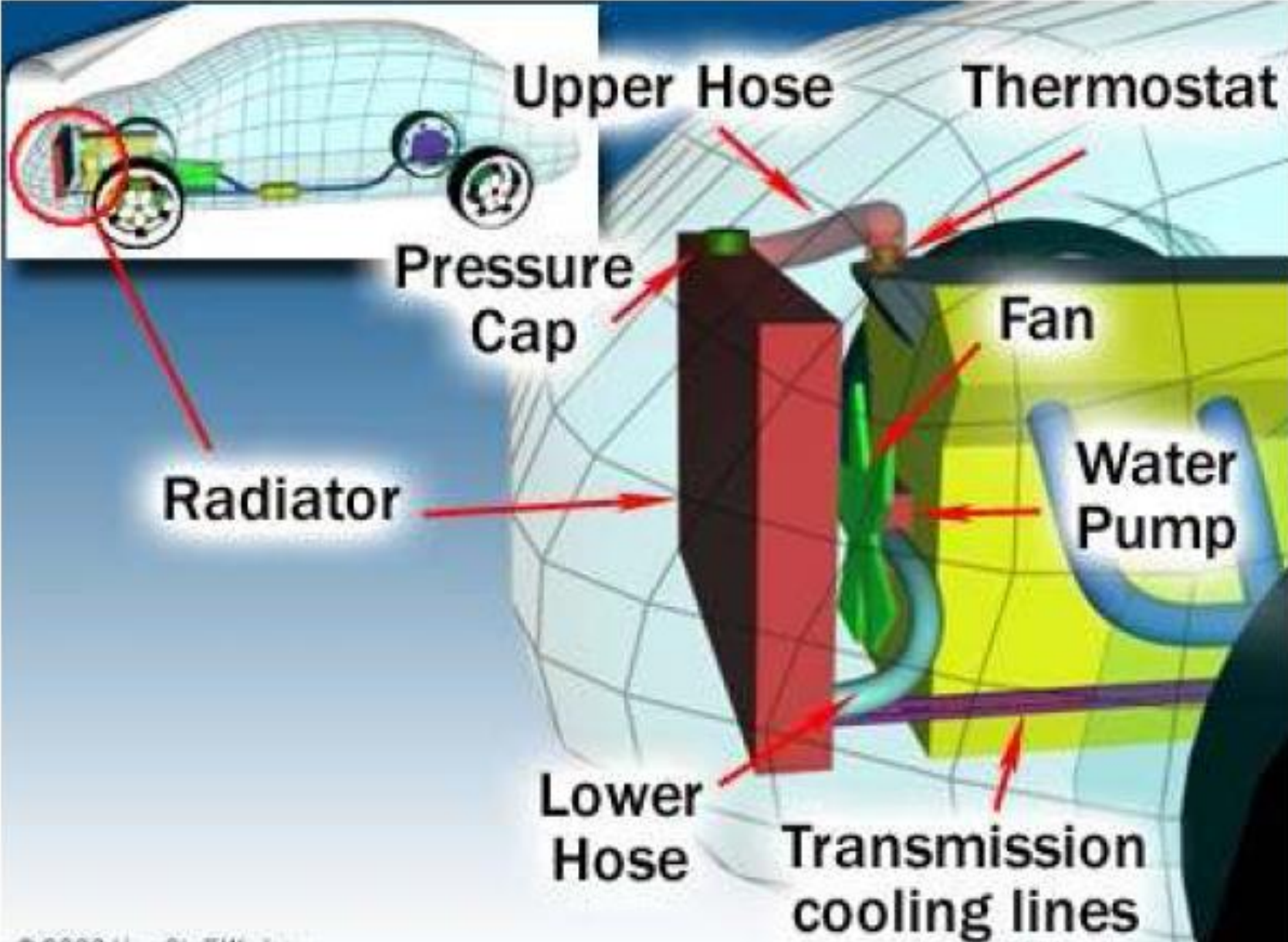

# Liquid cycle In the system

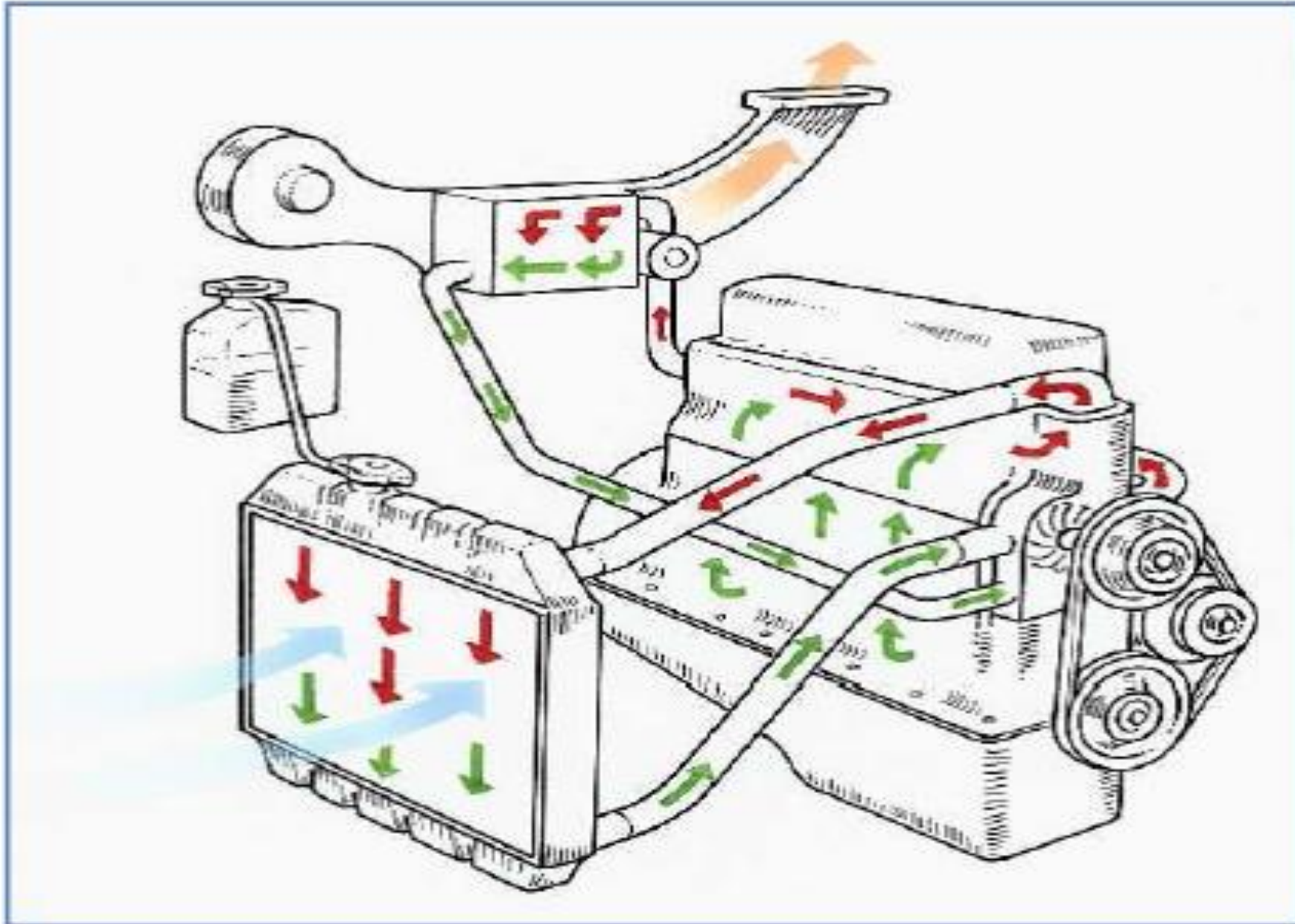



# Engine liquid passageways



## Induction of Fuel in SI Engine

- The task of the engine induction and fuel systems is to prepare from ambient air and fuel in the tank an air-fuel mixture that satisfies the requirement of the engine.
- This preparation is to be carried out over entire engine operating regime.
- In principle, the optimum air-fuel ratio for an engine is that which give the required power output with the lowest fuel consumption.
- It should also ensure smooth and reliable operation.
- The fuel Induction systems for SI engine are classified as:
  - Carburetors.
  - Throttle body Fuel Injection Systems.
  - Multi Point Fuel Injection Systems.



# The Carburetor: A Natural Fuel Induction System

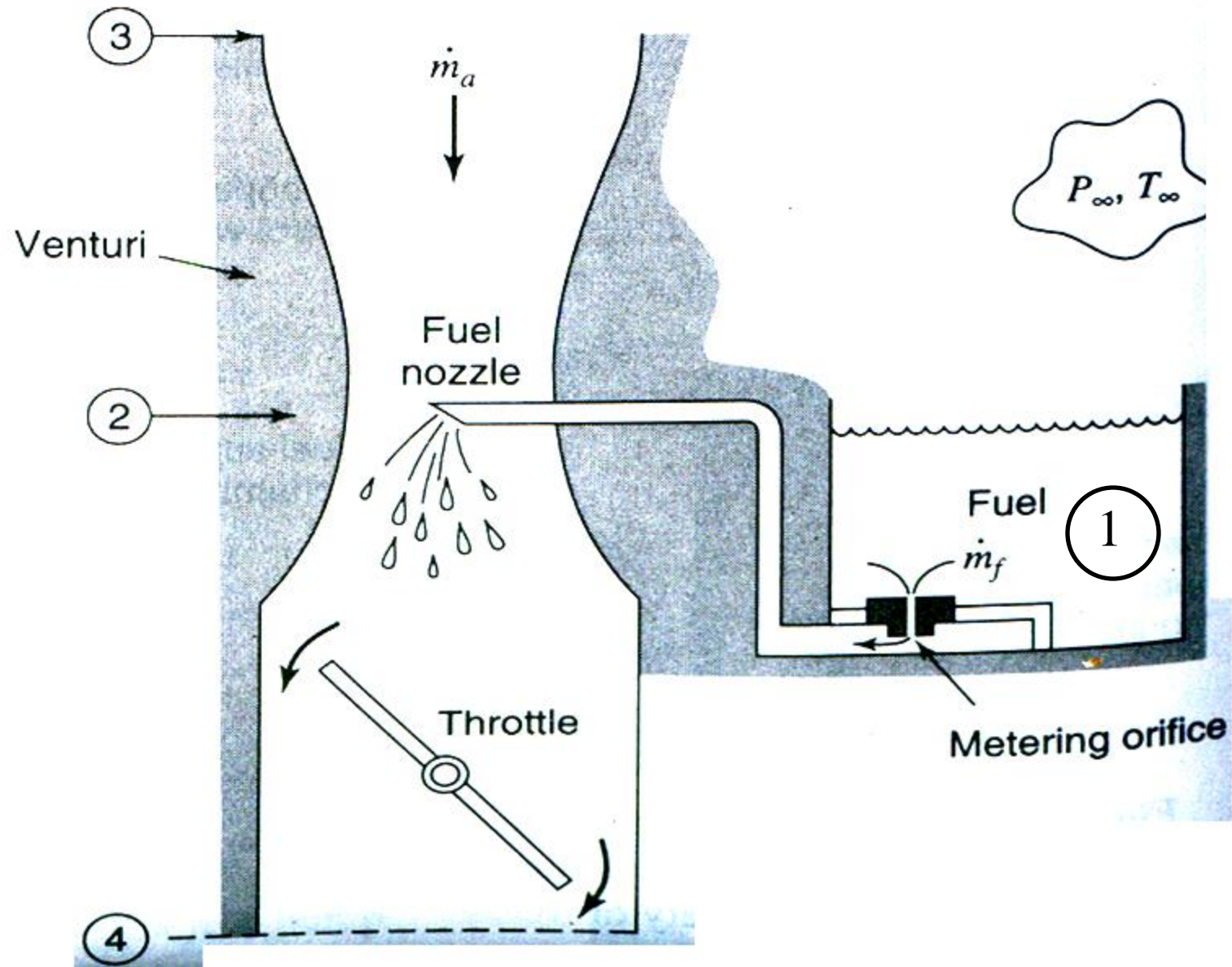

# Practical Carburetor Venturi

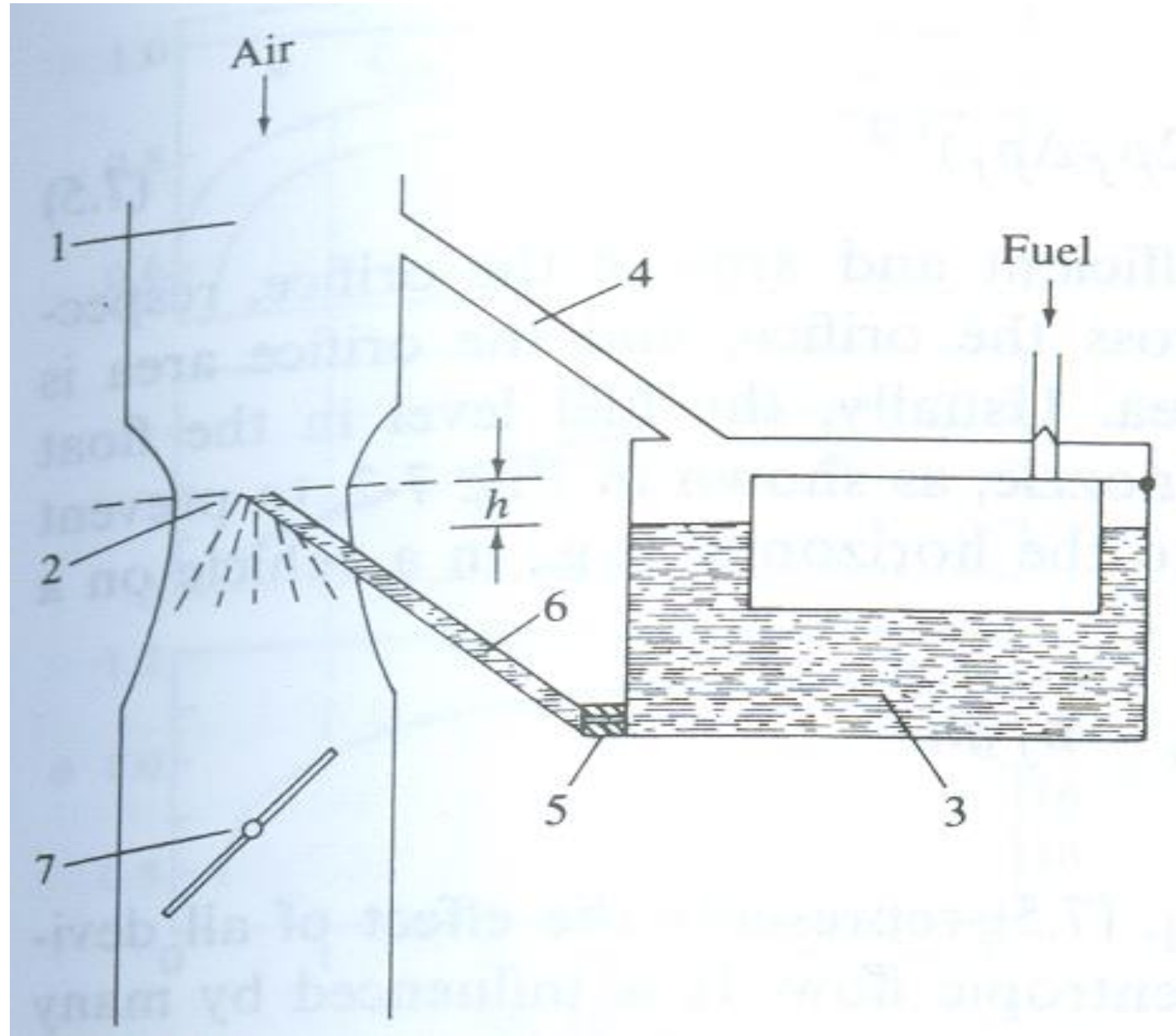



# Anatomy of EFI

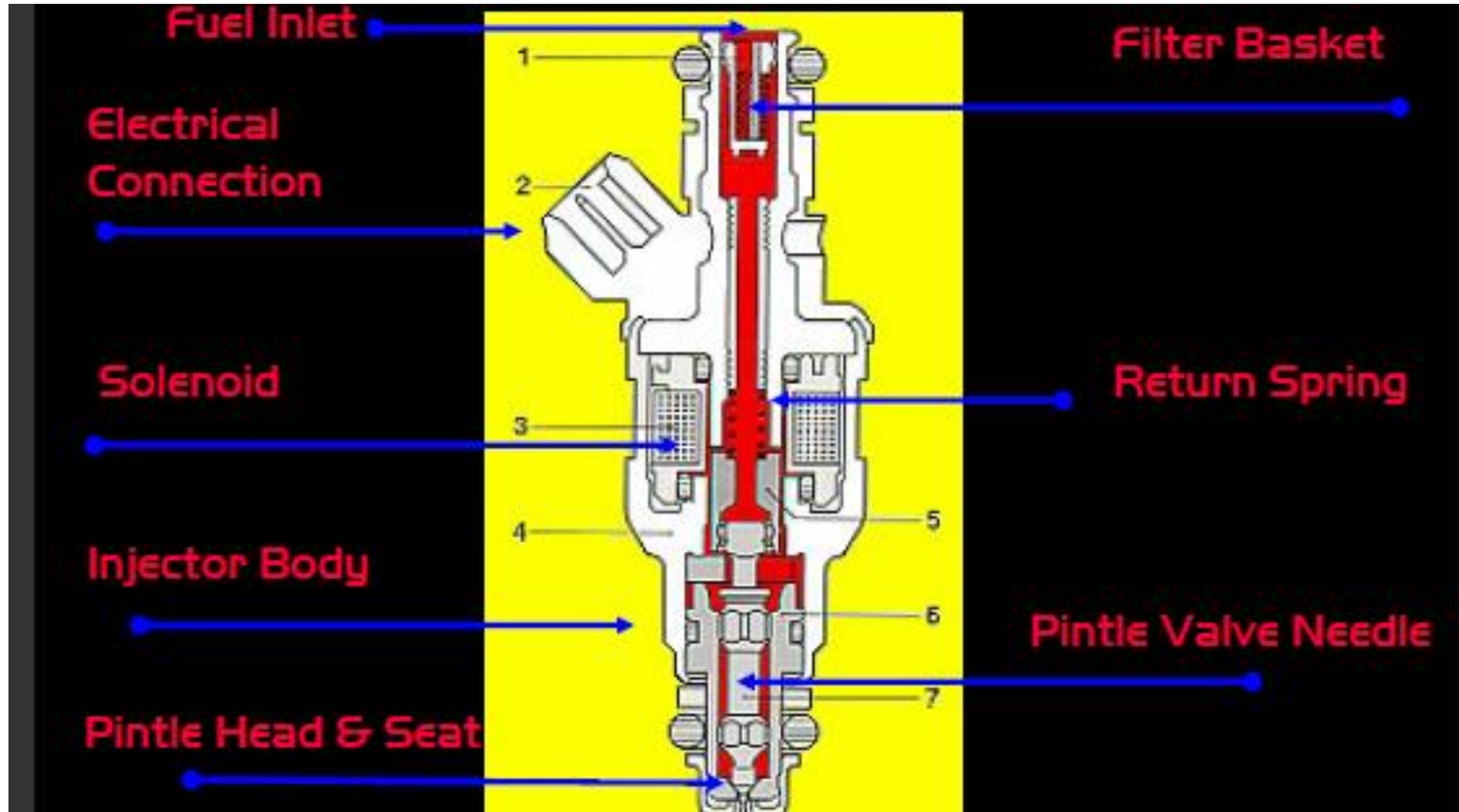

## Serviceable Parts of A EFI

The Electronic Injector is a sealed unit and cannot be dismantled or have any of its internal components replaced.

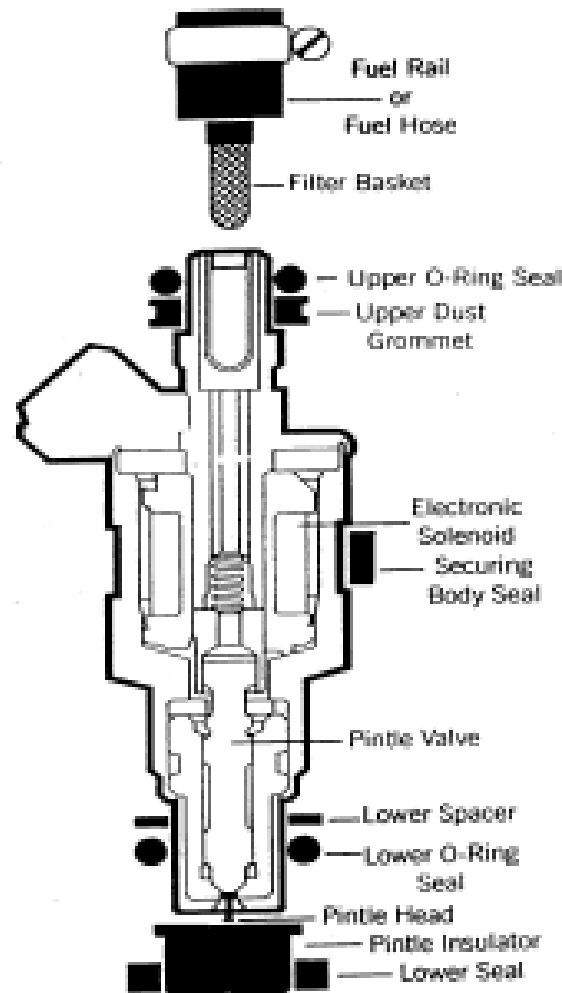

Only the external components and internal filter can be replaced. All rubber Fuel & Air seals should be replaced if injector are removed from engine



# Measurement of Quality of Injection

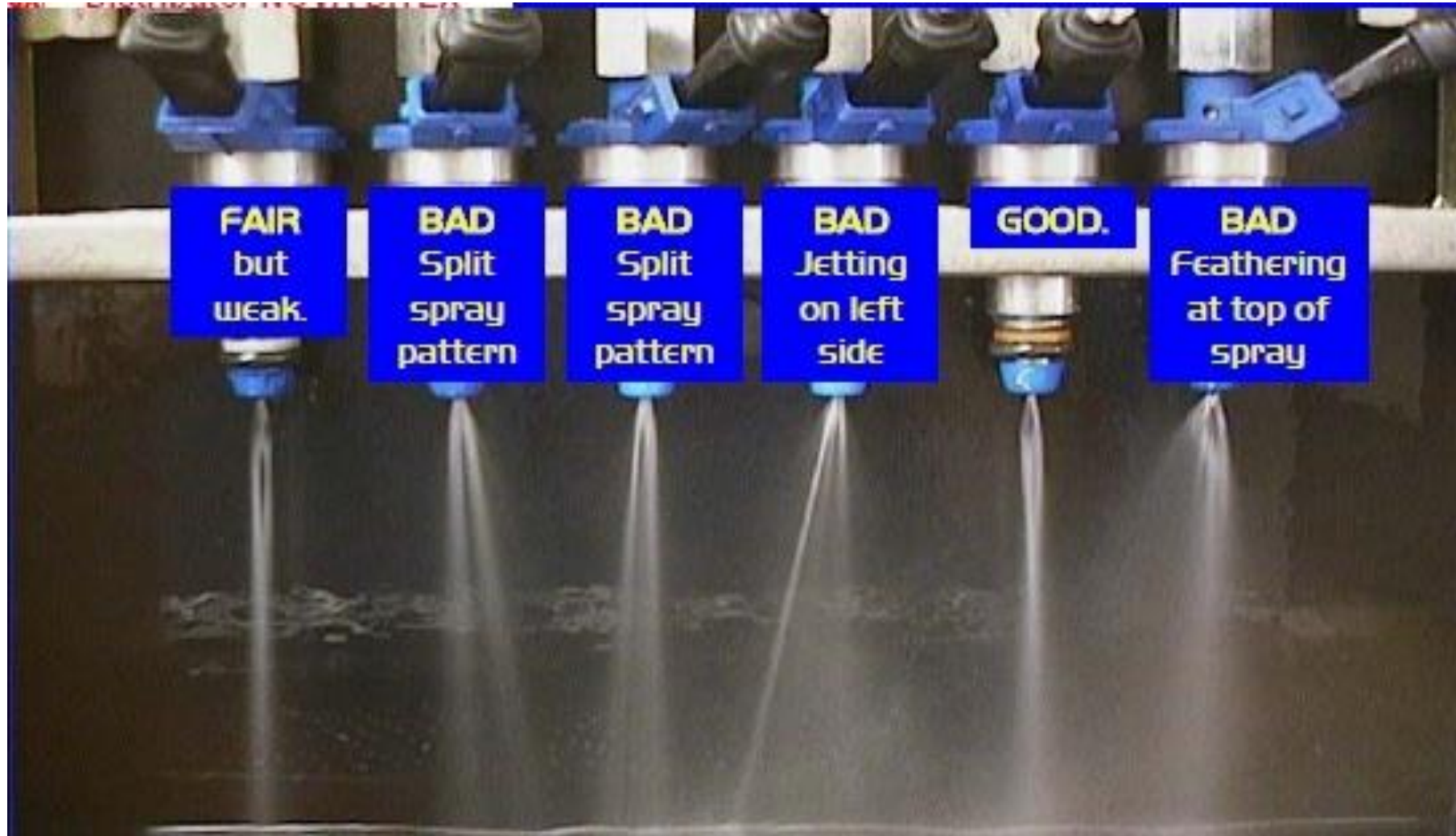

*The Spray Pattern Generated by an Injector*





## Types of Fuel Induction Systems : SI Engines

- The fuel Induction systems used in SI engine are classified as:
  - Carburetors.
  - Throttle body Fuel Injection Systems.
  - Multi Point Fuel Injection Systems.
  - Direct Gasoline Injection System

# Evolution of Fuel Induction Systems : SI Engines – First Generation

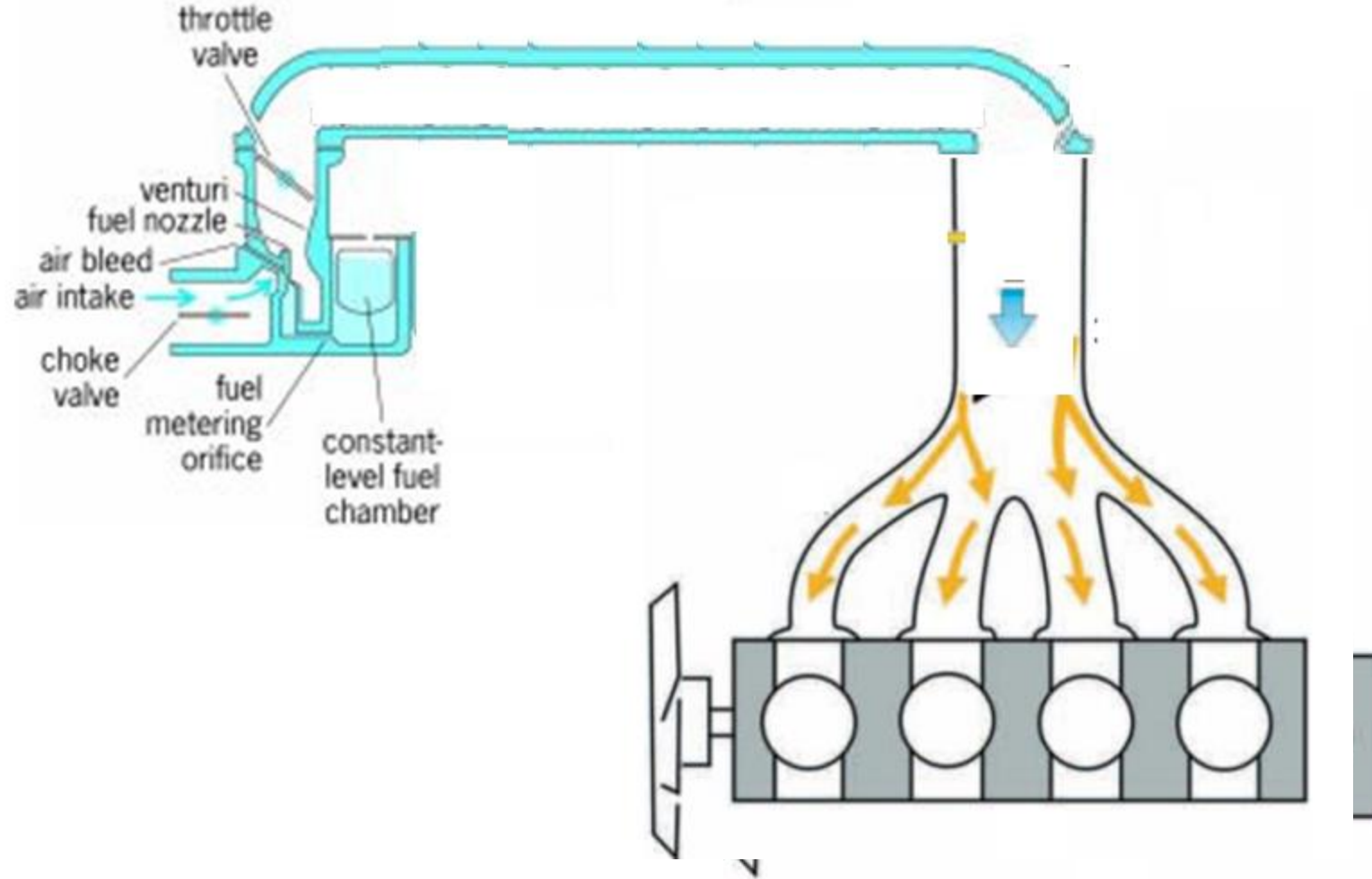



## Evolution of Fuel Induction Systems : SI Engines – Second Generation

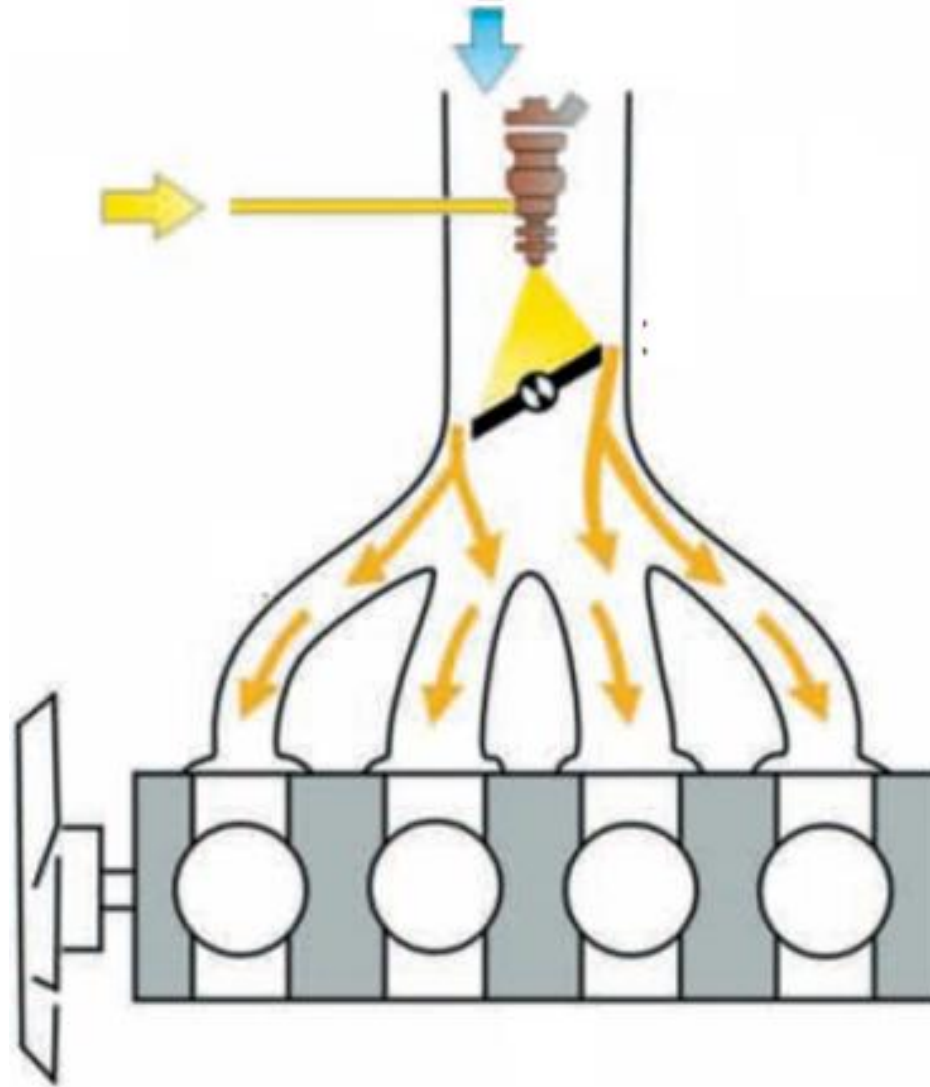

# Evolution of Fuel Inductions Systems : Third Generation

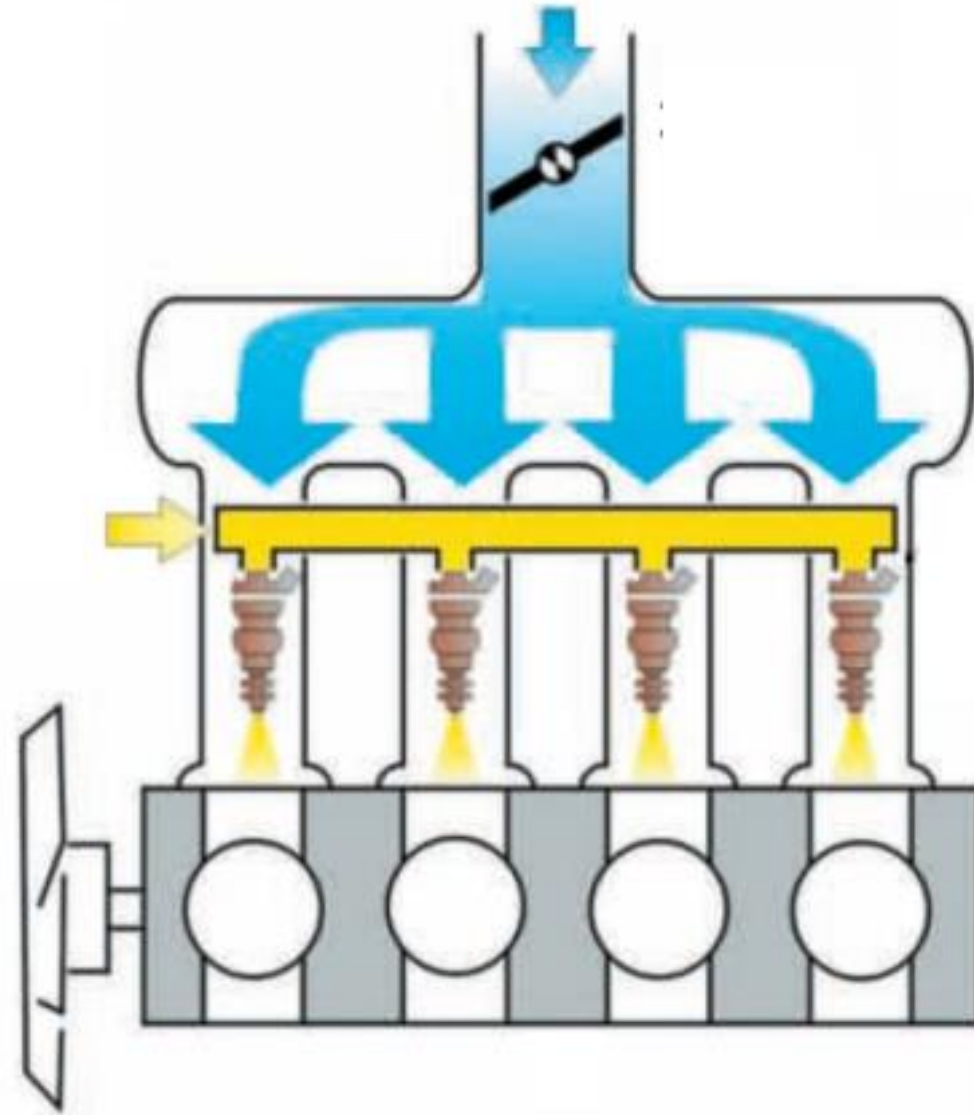

# Evolution of Fuel Inductions Systems : Next Generation

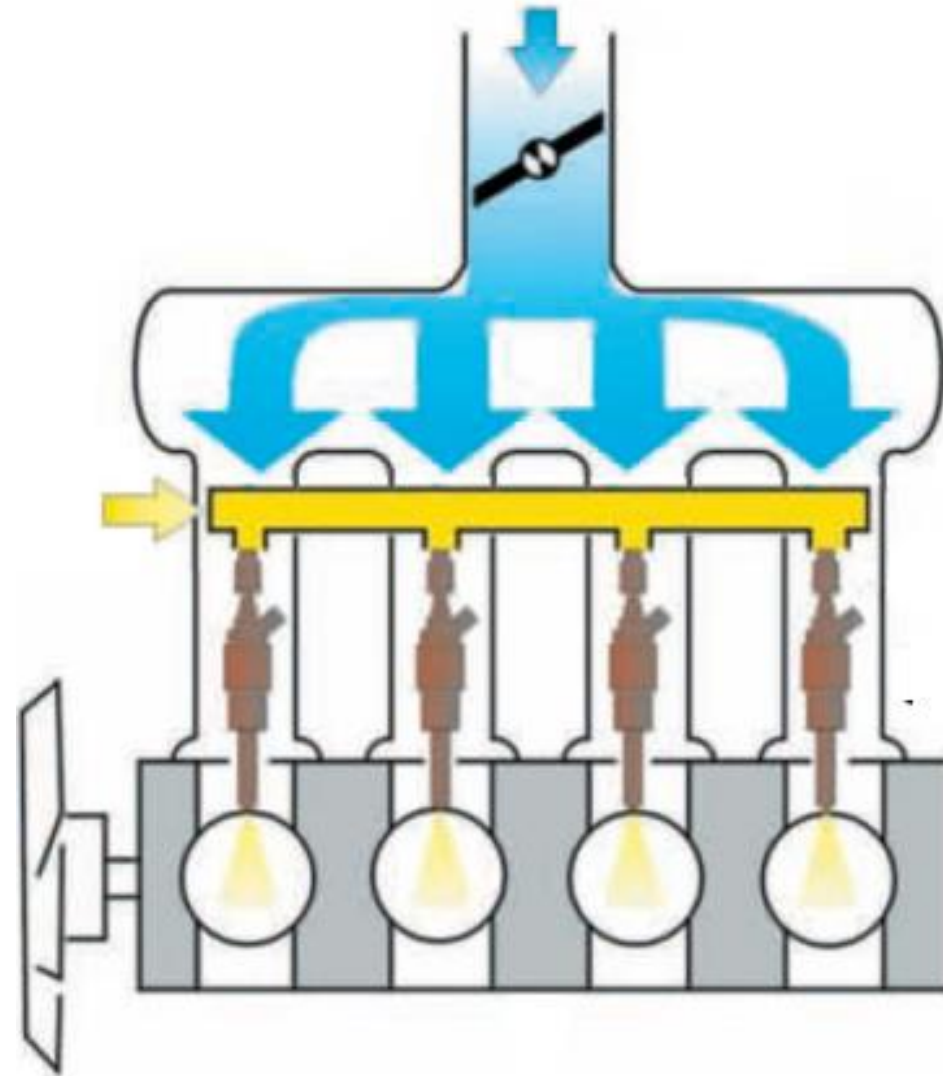



## ❖ History:

- In 1901 an American, William W. Humphreys, patented an idea - a 'Pneumatic Spring for Vehicles.
- From 1920, Frenchman George Messier provided aftermarket pneumatic suspension systems.
- During World War II, the U.S. developed the air suspension for heavy aircraft in order to save weight with compact construction.
- In 1954, Frenchman Paul Magès developed a functioning air/oil hydro-pneumatic suspension, incorporating the advantages of earlier air suspension concepts.
- GM introduced air suspension as standard equipment on the new 1957 Cadillac Eldorado Brougham.
- Dunlop Systems UK were also pioneers of Electronically Controlled Air Suspension (ECAS) for off road vehicles - the term ECAS was successfully trade marked. The system was first fitted to the 93MY Landrover Rangerover.

- Air suspension is used in place of conventional steel springs in passenger cars, and in heavy vehicle applications such as buses and trucks. It is broadly used on semi trailers, trains (primarily passenger trains).
- The purpose of air suspension is to provide a smooth, constant ride quality, but in some cases is used for sports suspension.
- Modern electronically controlled systems in automobiles and light trucks almost always feature self-leveling along with raising and lowering functions.
- Although traditionally called **air bags** or **air bellows**, the correct term is **air spring** (although these terms are also used to describe just the rubber bellows element with its end plates).



## ❖ Braking System:

- The function of the braking system is to retard the speed of the moving vehicle or bring it to rest in a shortest possible distance whenever required.
- The vehicle can be held on an inclined surface against the pull of gravity by the application of brake. Brakes are **mechanical devices for increasing the frictional resistance that retards the turning motion of the vehicle wheels.**
- It absorbs either kinetic energy or potential energy or both while remaining in action and this absorbed energy appears in the form of heat.
- While moving down a steep gradient the vehicle is controlled by the application of brakes. In this case brakes remain in action for a longer period making it imperative to dissipate the braking heat to atmosphere as rapidly as possible



- Automobiles are fitted with two brakes; **the service or foot brake and the emergency or hand brake**. The foot brake is used to control the speed of the vehicle and to stop it, when and where desired, by the application of force on the brake pedal.
- The hand brake, applied by a lever, is used to keep the vehicle from moving when parked. **Hand brakes are called emergency brakes** because **they are applied when the service brake fails**.
- Virtually all vehicles are now equipped with 4-wheel brakes. The front brakes must operate without interfering with the steering action.
- The brakes must be capable of decelerating a vehicle at a faster rate than the engine is able to accelerate it. Normally brakes have to **absorb three times the amount of engine horsepower** energy in its equivalent form.

## ❖ **Functions of Braking System**

- To stop the vehicle safely in shortest possible distance in case of emergency.
- To control the vehicle when it is descending along the hills.
- To keep the vehicle in desired position after bringing in at rest.

## ❖ Requirements of Braking System

1. Brakes must be strong enough to stop vehicle with in a minimum distance in an emergency.
2. Brakes must have good anti-fade characteristics i.e. their effectiveness should not decrease with prolonged application. This requirement demands cooling of brakes should be very efficient.
3. The retardation should be smooth and free from jerk or shudder.
4. Not to be affected by water, heat, road grit and dust etc.
5. Permit the operator to retain control of the vehicle must not skid when brakes are applied
6. Adequate durability with economical maintenance and adjustment
7. High reliability and highest degree of safety on road





## ❖ **Brake Force Required to Stop the Vehicle :**

- A vehicle with a 100 hp engine require about 60 sec to accelerate the vehicle from 0 to 100 kmph. If the same vehicle is required to be stopped from 100kmph to 0 kmph in not more than 6 sec then brakes must do the same amount of work as engine did but in one tenth of the time. This means brakes must develop 1000 hp to stop the vehicle .
- **If the weight of the vehicle is doubled then brake power must be doubled.**
- **If the speed of the vehicle is doubled then stopping power must be four times.**
- **If both weight and speed is doubled then brake power must be increased 8 times.**

2,000 pounds  = 60,200 foot pounds of energy  
30 mph →

4,000 pounds  = 120,400 foot pounds of energy  
30 mph →

2,000 pounds  = 60,200 foot pounds of energy  
30 mph →

2,000 pounds  = 240,802 foot pounds of energy  
60 mph →

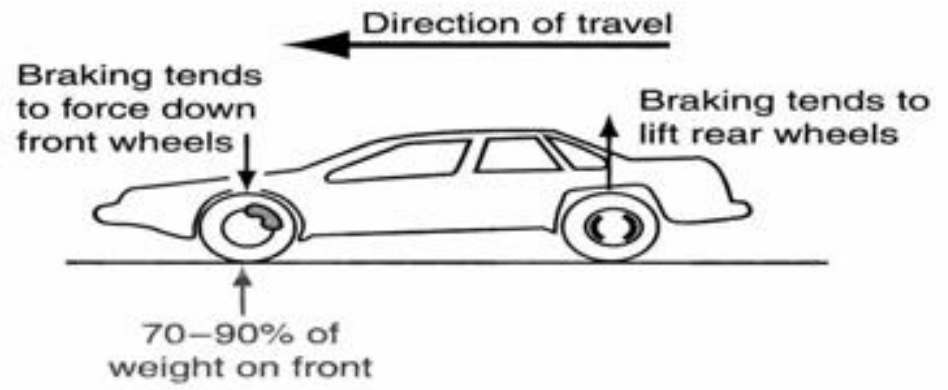

### ❖ Capacity of a Brake :

- Unit pressure between the braking surfaces.
- Coefficient of friction between the braking surfaces.
- Projected area of the braking surfaces.
- Peripheral velocity of the brake drum.
- Ability of the brake to dissipate heat equivalent to the energy being absorbed



## ❖ Braking Fundamentals

- Kinetic energy is the force that keeps the vehicle moving. This energy is provided by the engine in order to accelerate the vehicle from a standstill to desired speed. Kinetic energy is dissipated as heat by the brakes during application of breaks (Fig.). The kinetic energy of a vehicle during braking is given by

$$KE = (1/2) (W/g) (U^2 - V^2) = (1/2) M (U^2 - V^2)$$

where,  $W$  = vehicle gross weight, N

$U$  = initial velocity, m/s

$V$  = final velocity, m/s

$M$  = Mass of the vehicle, kg

$g$  = acceleration due to gravity, m/s<sup>2</sup>

- Thus, the kinetic energy doubles as the weight doubles, but it increases four times as speed doubles.

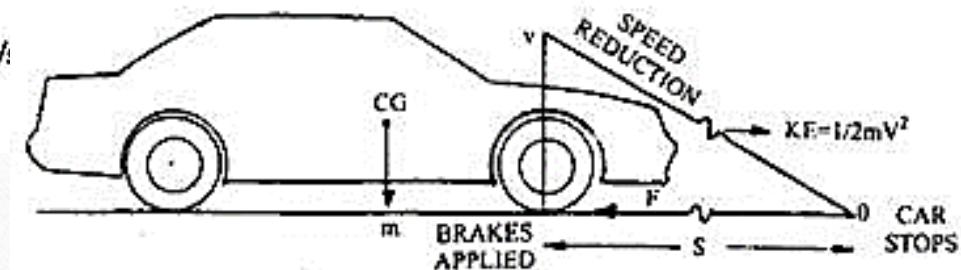

## ❖ Coefficient of Friction.

- Frictional force opposes the motion of the vehicle. Consequently it consumes power and produces heat. Frictional force occurs between the sliding tire and the road surface when wheel rotation is locked by brakes.
- The ability of a vehicle to stop depends on the coefficient of friction between the contacting surfaces. Maximum useable coefficient of friction occurs between the **tyre and road surface**. Passenger car brakes have coefficient of friction **0.3 to 0.5**.
- The amount of energy that can be absorbed by the brakes depends upon the **coefficient of friction of the brake materials, brake diameter, brake surface area, shoe geometry, and the pressure used to actuate the brake**. Stopping a car suddenly means very high friction, resulting in high brake temperature.

$$F_R = \mu R$$

- The value of Coefficient of friction depends on several factors:
  - Road surface condition.
  - Tyre tread pattern.
  - Inflation pressure (Correct, over or under –inflated.)
  - Material of road surface.



## ❖ Brake Safety.

- All automobiles are equipped with an emergency brake that would operate independently from the service brakes.
- Safety standard require the emergency brake to hold the automobile on a 30% slope indefinitely after the brake has been applied until the operator releases it.

## ❖ Classification of Brakes

- **1.By method of power**

- a) Mechanical brakes
- b) Hydraulic brakes
- c) Air brakes
- d) Vacuum brakes
- e) Power assisted hydraulic brakes
- f) Magnetic brakes
- g) Electrical brakes

- **2.By method of application:**

- a) Service or foot brakes
- b) Parking or hand brakes

- **3. By method of operation:**
- a) Manual
- b) Servo
- c) Power operation
- **4. By method of Braking contact**
- a. Internal Expanding Brakes
- b. External Contracting Brakes
- **5. By Method of Applying Brake force:**
- a. Single Acting Brakes.
- b. Double Acting Brakes.



## ❖ **Mechanical Brakes:**

- The two main types of mechanical brake are drum brake and disc brake.
  - In both types a fixed (non-rotating) shoe or pad rubs against a moving drum or disc.
  - To increase the friction between the rubbing surfaces, a special friction material is attached to the fixed part.
  - Earlier this friction material had a high content of asbestos, but its dust is injurious to health so that a safe asbestos free friction material is nowadays used.
1. Drum Brakes (Internal Expanding or External Contracting)
  2. Disc Brakes

## ❖ Drum Brakes:

- The main components of drum brakes are
- 1. Brake drum
- 2. Back plate
- 3. Brake shoes
- 4. Brake Liners
- 5. Retaining Springs
- 6. Cam
- 7. Brake Linkages

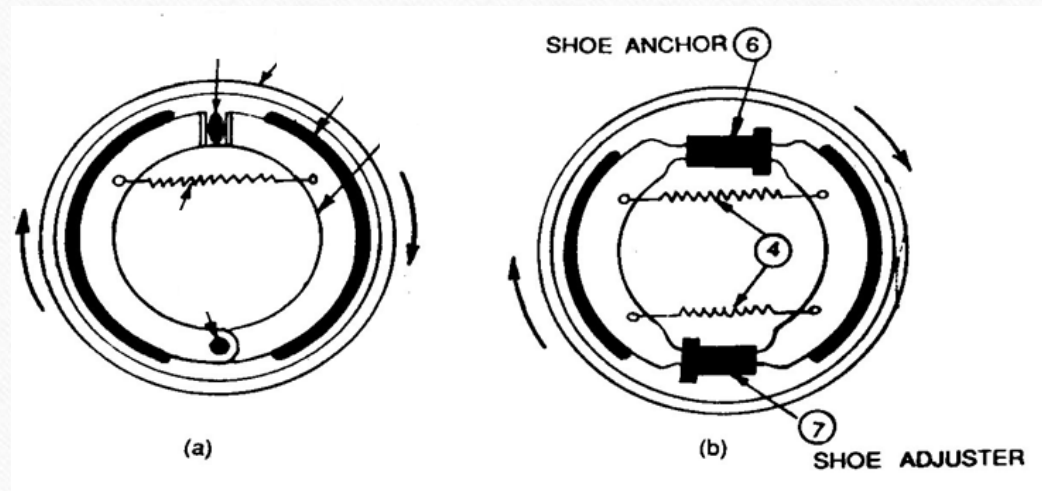
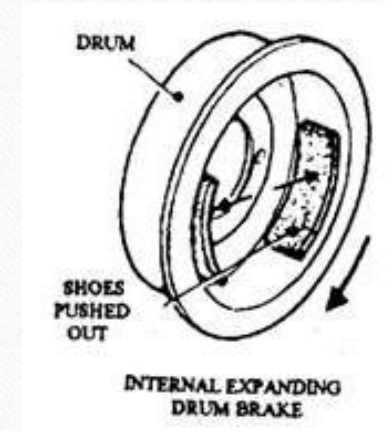



- This internal expanding type of brake contains two shoes that are attached to a back-plate and are fixed to a stub axle or axle tube.
- A friction lining is riveted or bonded to the outer face of the shoe. A drive is fitted at one end of the shoe so that the shoe expands when the brake pedal is applied. In a simple brake a cam is used as a shoe expander, but modern systems for cars use hydraulically operated pistons for shoe expansion.
- The shoe anchor is rigidly attached to the back-plate and takes the form of a large pin that passes through the shoes, or housing. The shoes butt against the anchor. Springs pull the brake shoes on the back-plate and also return the shoes to the 'off' position after the brake has been applied.
- In some layouts separate springs execute the retention and return functions.



- The inner cylindrical surface of the cast iron drum is made smooth on to which the brake linings rub. The drum is generally fixed to the hub flange using counter-sunk screws and secured by the wheel nuts.
- It is necessary to adjust excessive clearance due to wear of the friction facing, so that they are always positioned very close to the drum. This is carried out either manually adjusting the brakes periodically, or having an automatic adjuster that continually sets the shoes.

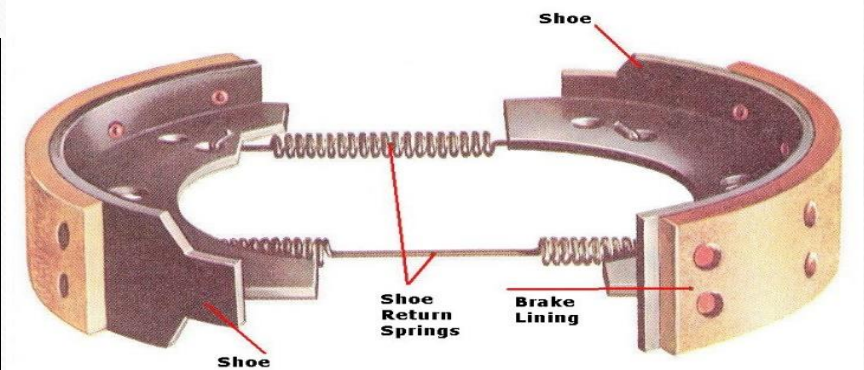
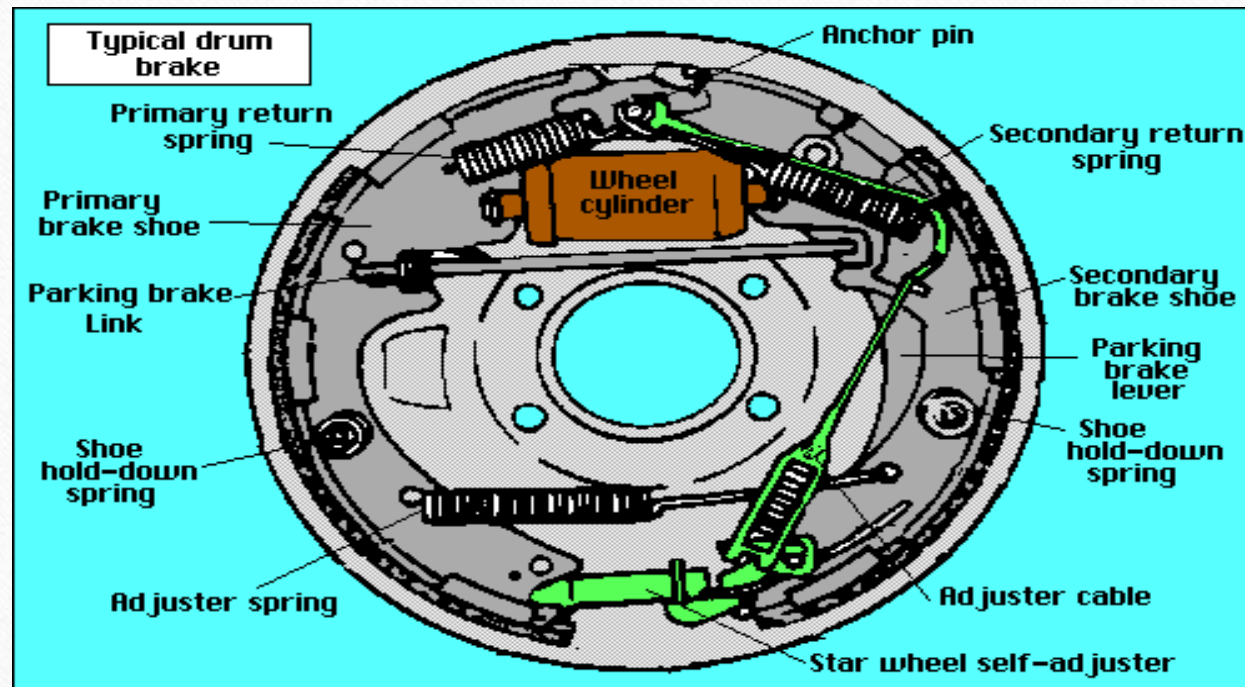

## ❖ Brake Layouts

- There are two types of drum brakes, such as externally contracting and internally expanding.
- The internal expanding type, along with a drum, is commonly used in braking systems of vehicles. The drum brakes, used with light vehicles, are hydraulically operated.
- These brakes are commonly used for the rear wheels to complement a disc system at the front. This disc/drum layout permits the front wheels to undertake more braking effort.
- In addition, the compatibility of a mechanical hand-brake with a drum brake makes this type an obvious option for rear brakes.
- **Various shoe arrangements in use include :**
  - Leading and trailing shoe (L&T)
  - Two leading shoe (2LS)
  - Duo-servo.



## ❖ **Leading and Trailing Shoe (L&T)**

- The layout of a leading and trailing shoe brake is presented in Fig. below. This arrangement uses a pair of shoes pivoted at a common anchor point. The free ends of both shoes are radially forced against the inside surface of the brake-drum using a double piston/cylinder expander.
- When the brake is applied with the vehicle stationary, hydraulic pressure pushes each shoe outwards and an equal force is applied by each shoe to the drum. But this applied force does not remain equal when the vehicle is moving (Fig. A below).
- The drag of the moving drum on the friction linings causes one shoe to be applied hard and the other to be pushed towards the 'off position.



- The shoe that does more work is called the leading shoe, and the other shoe is called the trailing shoe. The rate of lining wear of leading shoe is higher as it does more work than the trailing shoe.
- Therefore, leading shoe reaches its wear limit well before the trailing shoe, unless a thicker lining is used. If the direction of the drum is reversed, the leading shoe, however, is converted into a trailing shoe.

- The unequal wear pattern can be taken up by the floating pistons in the wheel cylinder in some layouts as shown in Fig. A. Otherwise, some provision is incorporated to adjust the brake shoes so that they are always centralized with respect to the drum

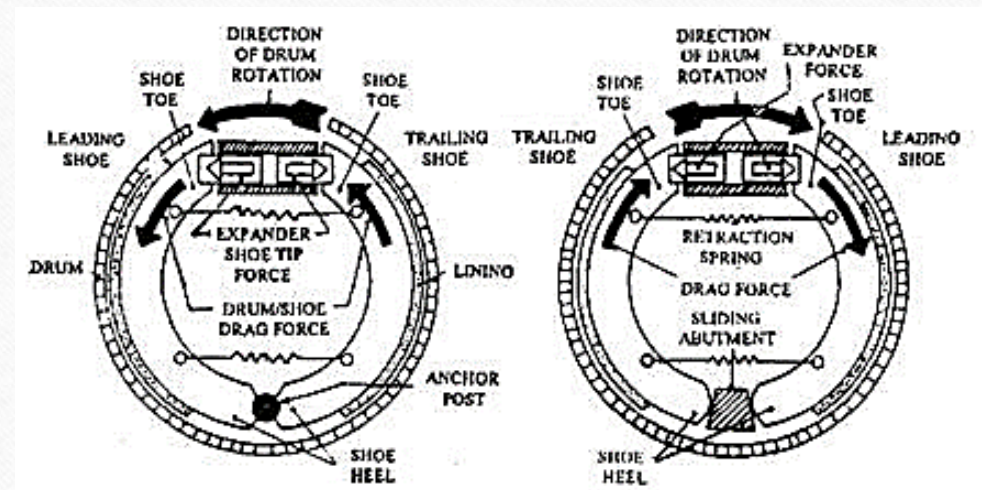

## ❖ Two Leading Shoe Brake (2LS)

- The 2LS system was in use for front brakes of vehicles before the adoption of the disc system. Each shoe of the 2LS arrangement uses its own expander; therefore both shoes can have self-servo action (Fig.28.17).
- An interlinking pipe fitted behind the back-plate provides an equal hydraulic pressure to each single-acting cylinder.
- Since the cylinder housings act as shoe anchors for the floating shoes, the cylinders are rigidly fixed to the back-plate.

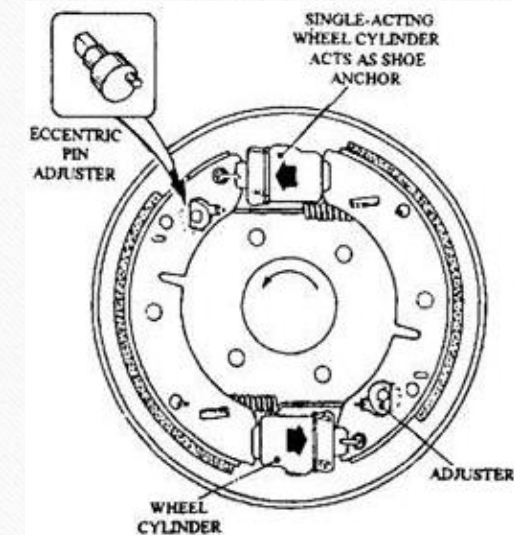
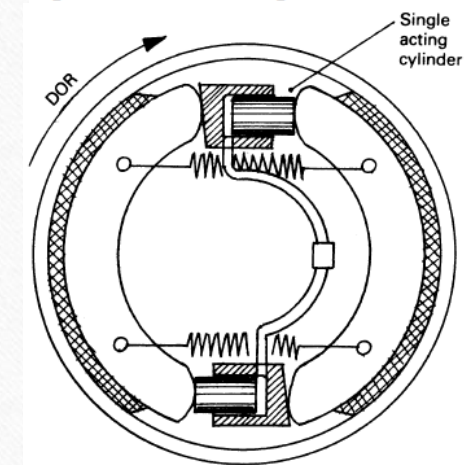

Fig. 28.17. Two leading shoe brake.



(b) Two leading shoes



❖ **2LS brake offers the following advantages over L&T shoe brakes:**

- Even lining wear- Because both shoes perform an equal amount of work, the brake runs cooler needing relatively less adjustment and has a long life.
- Equal self-servo action- Two effective shoes provide a more powerful and stable brake.
- Greater resistance to fade- Since both the shoes share the braking equally, the self-servo action on this shoe can be reduced so that a more progressive braking action, which is less sensitive to heat, is achieved.
- **One disadvantage** of the 2LS type is that unless a special double-acting linkage is incorporated, **both shoes change to trailing shoes during backward** movement of the car.
- To compensate for this problem L&T type brakes are used as rear brakes.



## ❖ Duo-servo Brake

- This brake arrangement is also known as the self-energizing brake. Although this is a very powerful brake, its effectiveness reduces severely with the decrease in the friction value.
- A hydraulically operated duo-servo brake is shown in Fig. 28.18. The principle of operation is based on the utilization of drum energy to considerably boost the force applied on the brakes by the driver.
- When the leading shoe is pushed to contact the forward-moving drum, it rotates partially with the drum due to the frictional force.

- This shoe movement, produced by this self-wrapping action, is conveyed through a floating adjuster to the trailing shoe so that the shoe is brought into contact with the drum.
- The force applied by the expander is supplemented by the self-energizing action of both shoes.
- To minimize the delay in application of the self-energization action, the trailing shoe is held on the anchor pin by a stronger return spring so that the expander only moves the leading shoe.
- In this arrangement, the leading shoe is called the primary shoe, because this shoe is made to contact the drum before the secondary shoe.

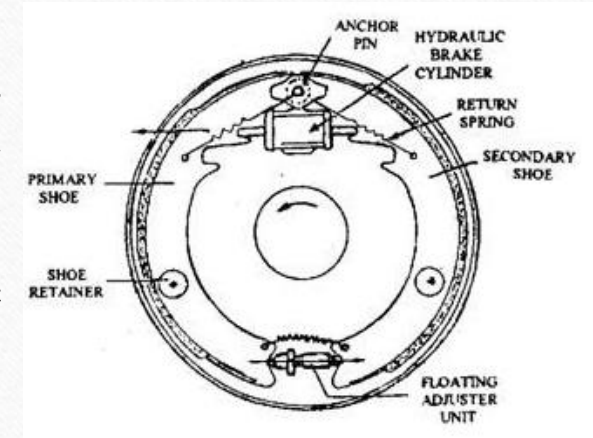
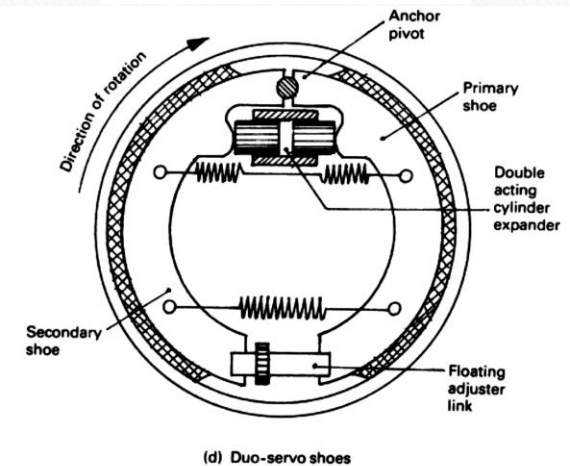

Fig. 28.18. Duo-servo brake.





## ❖ External contracting brake drum

- In external contracting brake drum has brake drum is used for only parking purpose. This system consist of Drum, brake & lining, operating lever with adjusting lever and push rod with returning spring.
- External braking system is model braking system used to operate in floor mills, various types of electrical components. the following various types of parts is applied on brake drum.

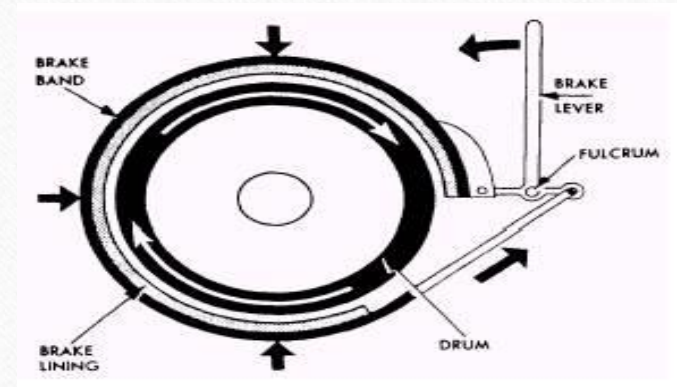



- The working system of external braking system, when push rod is operated by hand or foot operated lever, then the lined brake drum is fitted around the drum is tightened to lock or slow down the drum.
- When the brake is released the return springs bring the band brake back to its initial position.
- The system remains air opened; therefore dirt is being accumulated between the rubbing surfaces, which reduces the efficiency.

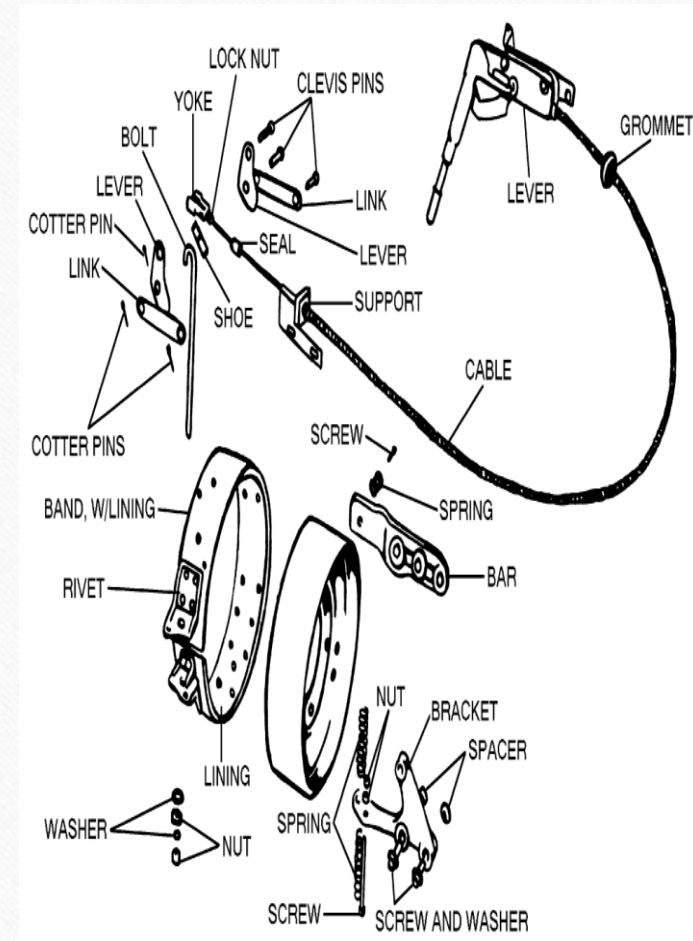

## ❖ Disc Brakes

- One problem with drum brakes is fade and to minimize this problem the disc brake was developed.
- It uses an exposed disc that is attached to the hub flange. The two friction pads are pressed on to this disc to provide braking action.
- The pads are actuated by hydraulic pistons placed in cylinders formed in a caliper, which is secured to a fixed part of the axle.
- The hydraulic pressure forces the friction pads against the rotating cast iron disc.

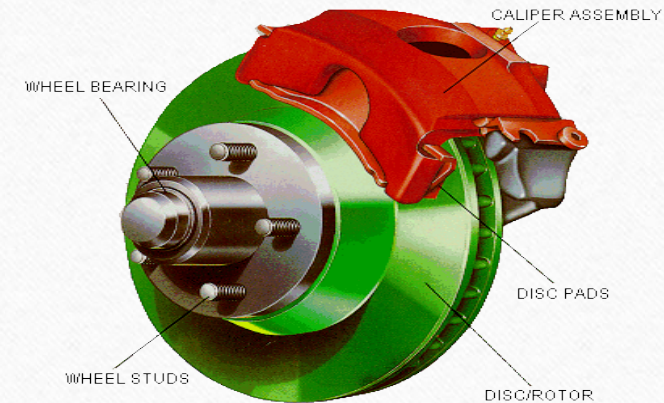
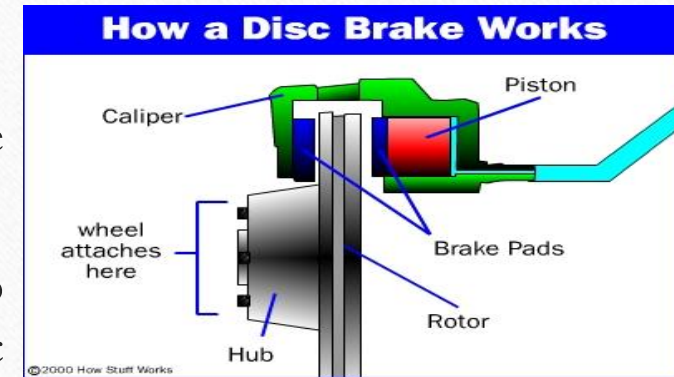



- Consequently, the disc motion is retarded and heat generated from the energy of motion is conducted to the disc.
- Since a large part of the disc is exposed to the air, heat is easily dissipated, so that the brake can be used continuously for long periods before serious fade occurs.
- In this layout the friction pads move at a right angle to the disc, so that any drop in the friction value does not affect the force applied to the pad.
- For the application of a disc brake, a greater pedal pressure is necessary to produce a given retardation than that required for a drum brake.
- Adjustment of pad wear is automatic on a disc brake. In this brake system the pads can also be inspected easily and in the absence of corrosion, the pads can be renewed easily



## ❖ Principle of the Disc Brake

- The disc brake consists of a circular plate disc mounted on to and rotated by the wheel hub and a bridge member, termed as the caliper. The caliper straddles the disc and is attached to the suspension carrier, stub axle or axle casing (Fig.)
- The caliper incorporates a pair of pistons and friction pads, which clamp the rotating disc during the application of the brakes. Consequently reduction of speed, proportional to the hydraulic pressure acting on each piston produced by the pedal effort, occurs.
- The normal clamping thrust,  $N$ , on each side of the disc (Fig.below) produces a frictional force,  $F = \mu N$ , at the interfaces of disc and pad on both sides of the disc.

- If the resultant frictional force acts through the centre of the friction pad then the mean distance between the centre of pad pressure and the centre of the disc becomes

$$\frac{R_2 + R_1}{2} = R$$

- where,  $R_1$  and  $R_2$  are the inner and outer diameter of the pad respectively.
- Accordingly, the frictional braking torque (Fig. A) is doubled due to the action of frictional force,  $N$  on both sides of the disc and depends upon the distance the pad is located from the disc centre of rotation.

- Therefore, the braking torque is given by  
$$T_B = 2 \mu N \left( \frac{R_2 + R_1}{2} \right) = 2 \mu NR, \text{ Nm.}$$



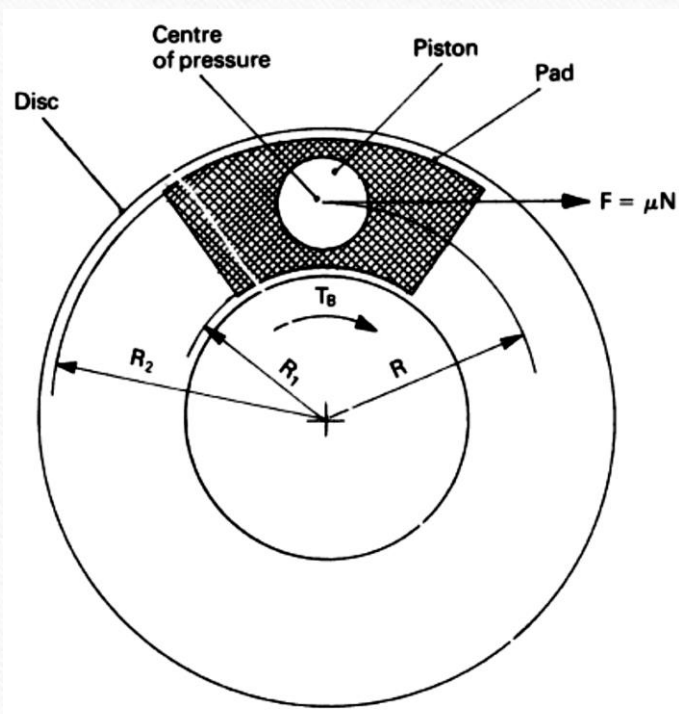

(a) Front view

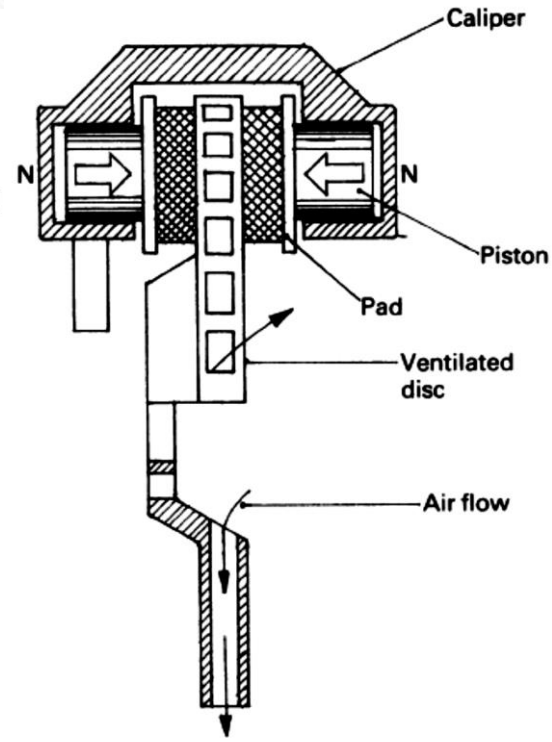

(b) End view

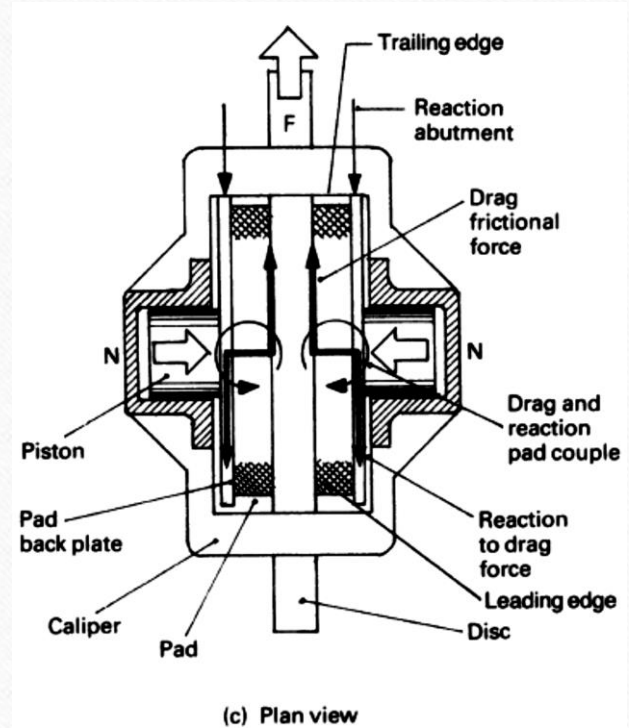

(c) Plan view



## ❖ Disc Brake Pad Alignment

- During the application of brake, the pads are pressed against the disc with uniform pressure. However a slight tilt tendency exists between the leading and trailing pad edges due to frictional pad drag. Additionally the rate of wear from the inner to the outer pad edges is not uniform.
- The thickness of the pad provides a small offset between the pad/disc interface and the pad's back plate reaction abutment within the caliper (Fig. b above).
- This produces a couple, which presses the pad harder against the disc at its leading edge compared to the trailing edge. Consequently this effect causes a very small self-energizing servo action, due to which the wear rate at the leading edge is relatively higher than that at the trailing edge.

- As the disc sweeps across the pad face, the circular distance it covers in one revolution increases proportionately from the inner to the outer edges of pad (Fig. A above).
- Consequently the rubbing speed, and hence the work done increases from the inner to the outer edges, due to which the pad temperature and wear per unit area rises with the increase in the radial distance from the disc centre.



## ❖ Disc Brake Pad Support Arrangements

### • 1. Swing Yoke Type Brake Caliper

- This disc brake caliper is a single cylinder unit and is of light weight. The caliper unit uses a rigid yoke of steel pressing, a cylinder assembly, two pads and a carrier bracket bolted to the suspension hub carrier.
- A tongue and groove joint rigidly secure the cylinder to one side of the yoke frame while the yoke itself pivots at one end on its supporting carrier bracket.
- The disc is mounted on the transmission drive shaft hub which provides the drive to the disc. The lining pads are supported on either side of the disc in the yoke frame (Fig. 11.19)

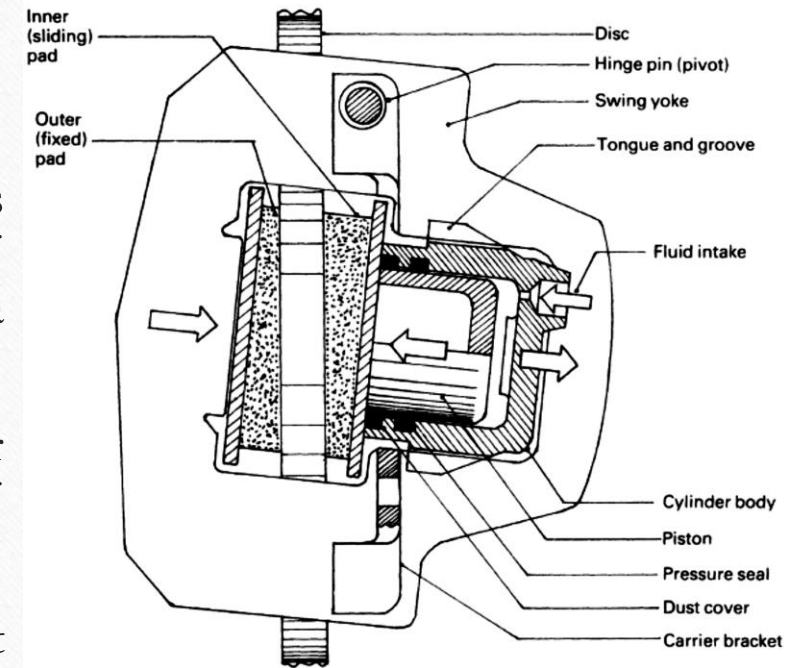
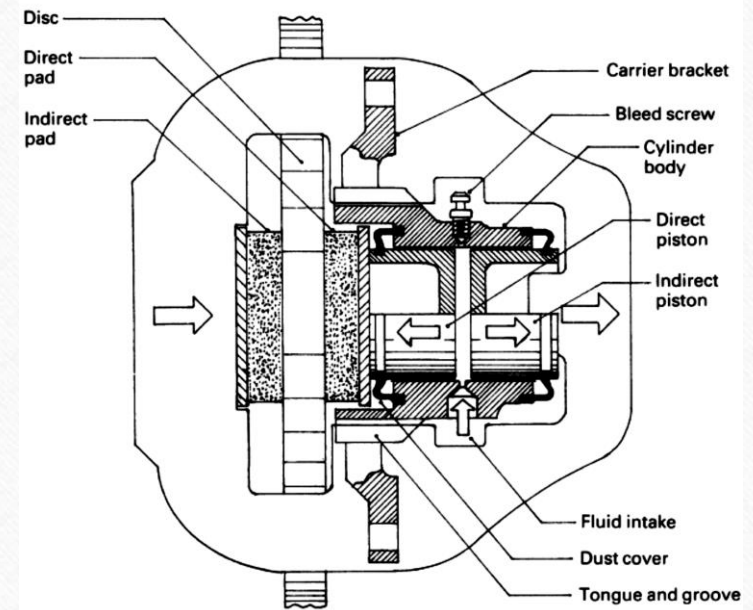

**Fig. 11.19** Swing yoke type brake caliper



- During operation of the foot brake, hydraulic pressure pushes the piston and inboard pad against their adjacent disc face.
- At the same time, the hydraulic reaction moves the cylinder in the opposite direction so that the outboard pad and cylinder body are bridged.
- Then the yoke pivots, forcing the outboard pad against the disc face opposite to that of the inboard pad. As the pads wear the yoke moves through an arc about its pivot.
- The lining pads are tapered in shape to compensate for this tilt. The operating clearance between the pads and disc is maintained roughly constant by the inherent distortional stretch and retraction of the pressure seals as the hydraulic pressure is increased and reduced respectively.

- **2. Sliding Yoke Type Brake Caliper**
  - In this type of caliper unit the cylinder body is rigidly fixed to the suspension hub carrier. The yoke slides between parallel grooves formed in the cylinder casting (Fig.11.20 ).
  - Application of the foot brake causes hydraulic pressure to push the pistons apart.
  - The direct piston forces the direct pad against the disc whereas the indirect piston forces the yoke to slide in the cylinder in the opposite direction until the indirect pad contacts the outstanding disc face.



**Fig. 11.20** Sliding yoke type brake caliper



- Further increase in pressure provides an equal but opposing force which sandwiches the disc between the friction pads.
- The rubber seals distort due to pressure increase as the pistons move apart. As the hydraulic pressure collapses the seals retract and withdraw the pistons and pads from the disc surface.
- Yoke rattle between the cylinder and yoke frame is minimized by incorporating either a wire or leaf spring between the sliding joints.



### 3. Sliding Pin Type Brake Caliper.

This type of disc brake caliper unit incorporates a disc, a carrier bracket, a cylinder caliper bridges, piston and seals, friction pads and a pair of support guide pins (Fig. 11.21 ).

The carrier bracket is bolted onto the suspension hub carrier. It supports the cylinder caliper bridge and absorbs the brake torque reaction. The cylinder caliper bridge is mounted on a pair of guide pins that slide in holes in the carrier bracket.

The guide pins only support and guide the bridge. These are sealed against dirt and moisture by dust covers. The frictional drag of the pads is absorbed by the carrier bracket. The application of the foot brake generates hydraulic pressure that pushes the piston and cylinder apart.

The inboard pad moves up to the inner disc face. In contrast, the cylinder and bridge react in the opposite direction until the outboard pad touches the outside disc face. Further increase of hydraulic pressure imposes equal but opposing forces against the disc faces via the pads.

- Similar to all other types of caliper units, in slide pin type also, the brake calipers pad to disc free clearance is provided by the pressure seals.
- The pressure seals are fitted inside recesses in the cylinder wall. They grip the piston when hydraulic pressure forces the piston outwards, getting distorted in the process.
- When the foot brake is released the pressure is withdrawn from the piston crown and the strain energy of the elastic rubber pulls back the piston so that the pressure seal is restored to its original shape.

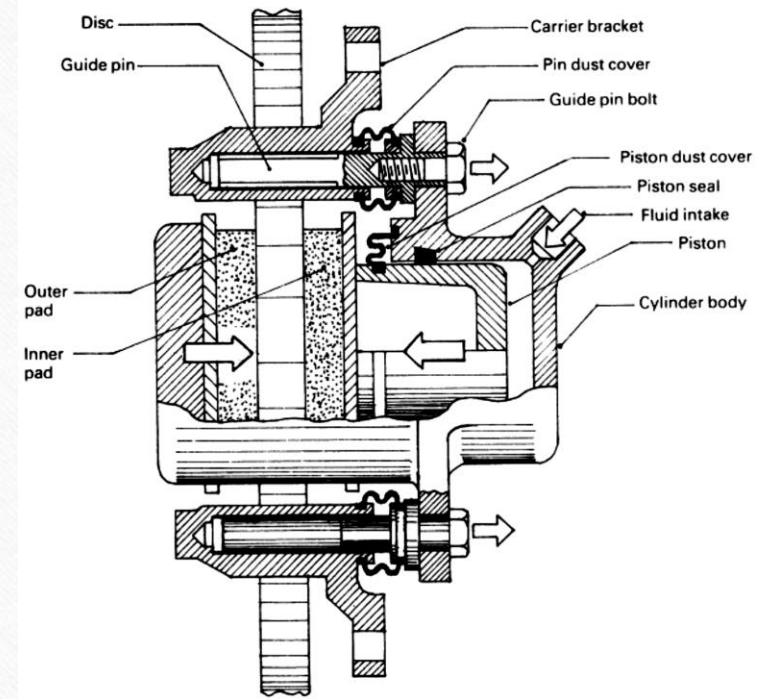

**Fig. 11.21** Slide pin type brake caliper



#### 4. Sliding Cylinder Body Type Brake Caliper.

- This type of brake caliper unit uses a carrier bracket bolted to the suspension hub carrier and a single piston cylinder bridge caliper.
- The caliper straddles the disc and slides laterally on guide keys located in wedge-shaped grooves formed in the carrier bracket (Fig. 11.22).
- The hydraulic pressure, generated due to the application of the foot brake, pushes the piston along with the direct acting pad onto the inside disc face.
- The cylinder body caliper bridge is pushed in the opposite direction, so that it reacts and slides in its guide groove at right angles to the disc.
- This causes the indirect pad to contact the outside disc face, equalizing the forces acting on both sides of the disc.



- A pad to disc face working clearance is provided as in the other units by the retraction of the pressure seal, after the hydraulic pressure collapses.
- Anti-rattle springs are incorporated alongside each of the two-edge-shaped grooves to avoid vibration and noise caused by the relative movements between the bridge caliper and carrier bracket sliding joint.

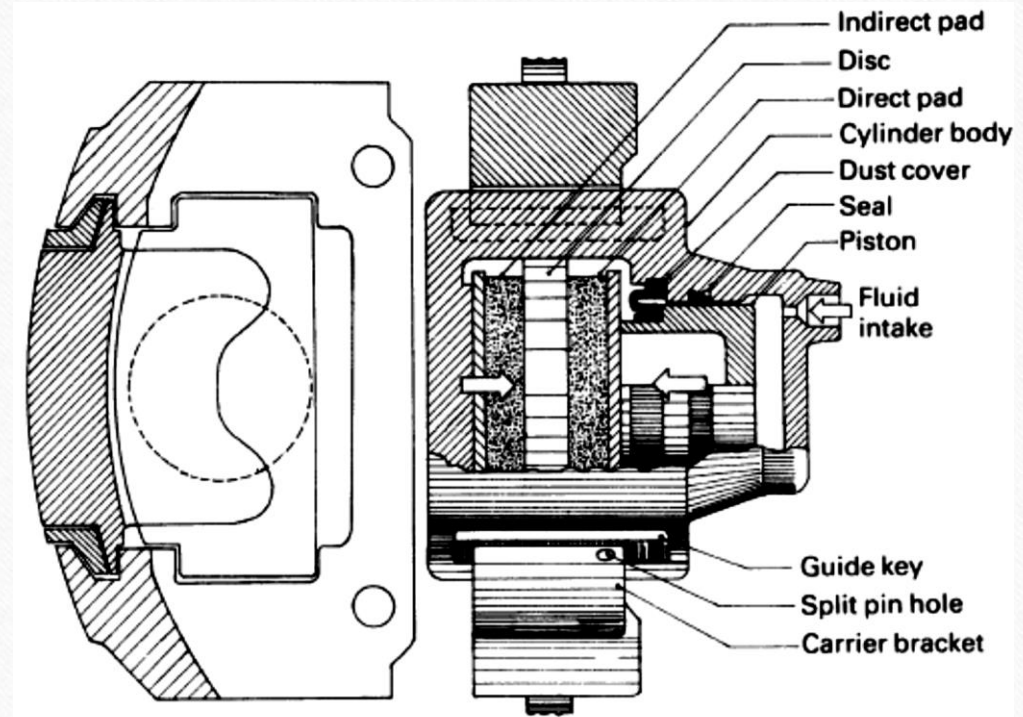

**Fig. 11.22** Slide cylinder body brake caliper

## ❖ A comparison of Shoe Factors and Shoe Stability

- Different brake shoe arrangements and the disc brake are compared on a basis of shoe factor,  $S$ , or output torque against the variation of rubbing coefficient of friction (Fig. 28.13).
- The coefficient of friction, however, for most linings and pads ranges between 0.35 and 0.45. The shoe factor in increasing order is roughly as presented in Table for the normal working range of the coefficient of friction.
- The figures in the table indicate that the torque output (shoe factor) for a single or two trailing shoes is only approximately one-third of the single or two leading shoe brake.



## ❖ Clutch:-

### ■ Principle:

- A **clutch** is a mechanical device that engages and disengages the power transmission, especially from driving shaft to driven shaft.
- It operates on the **principle of friction**. When two surfaces are brought in contact and are held against each other due to friction between them, they can be used to transmit torque.
- If one is rotated, then other also rotates.

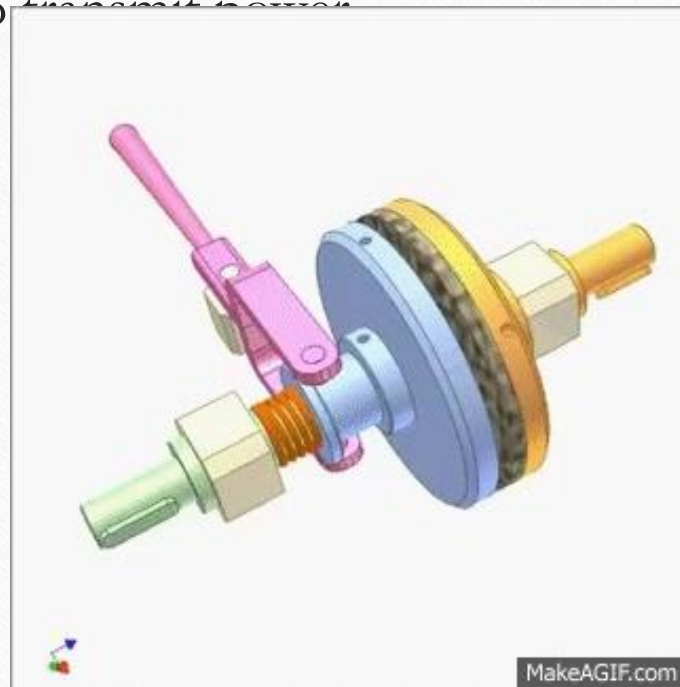

❖ Clutch Operation:

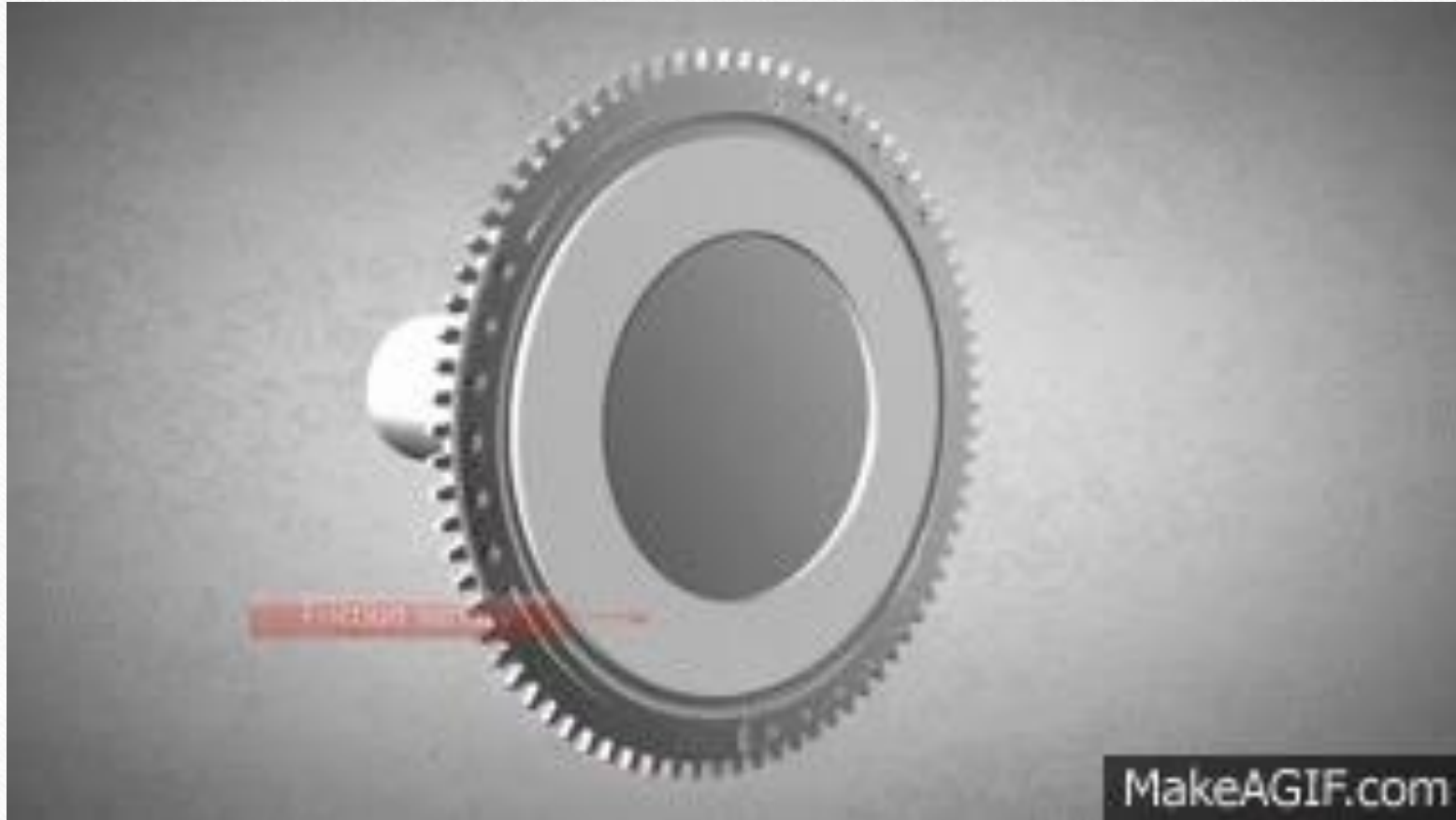



# CLUTCH SYSTEM

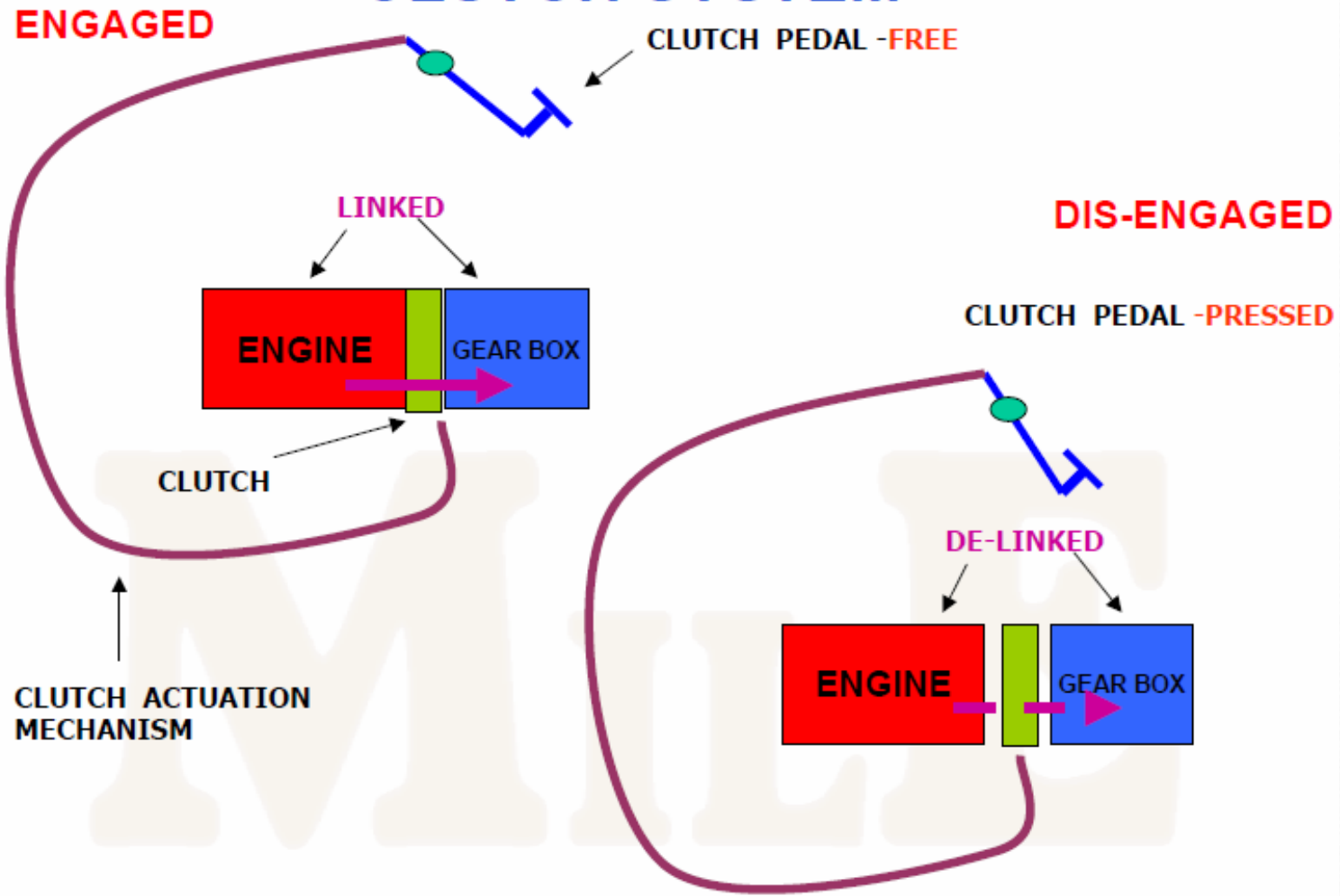

## ❖ Types of Clutches:

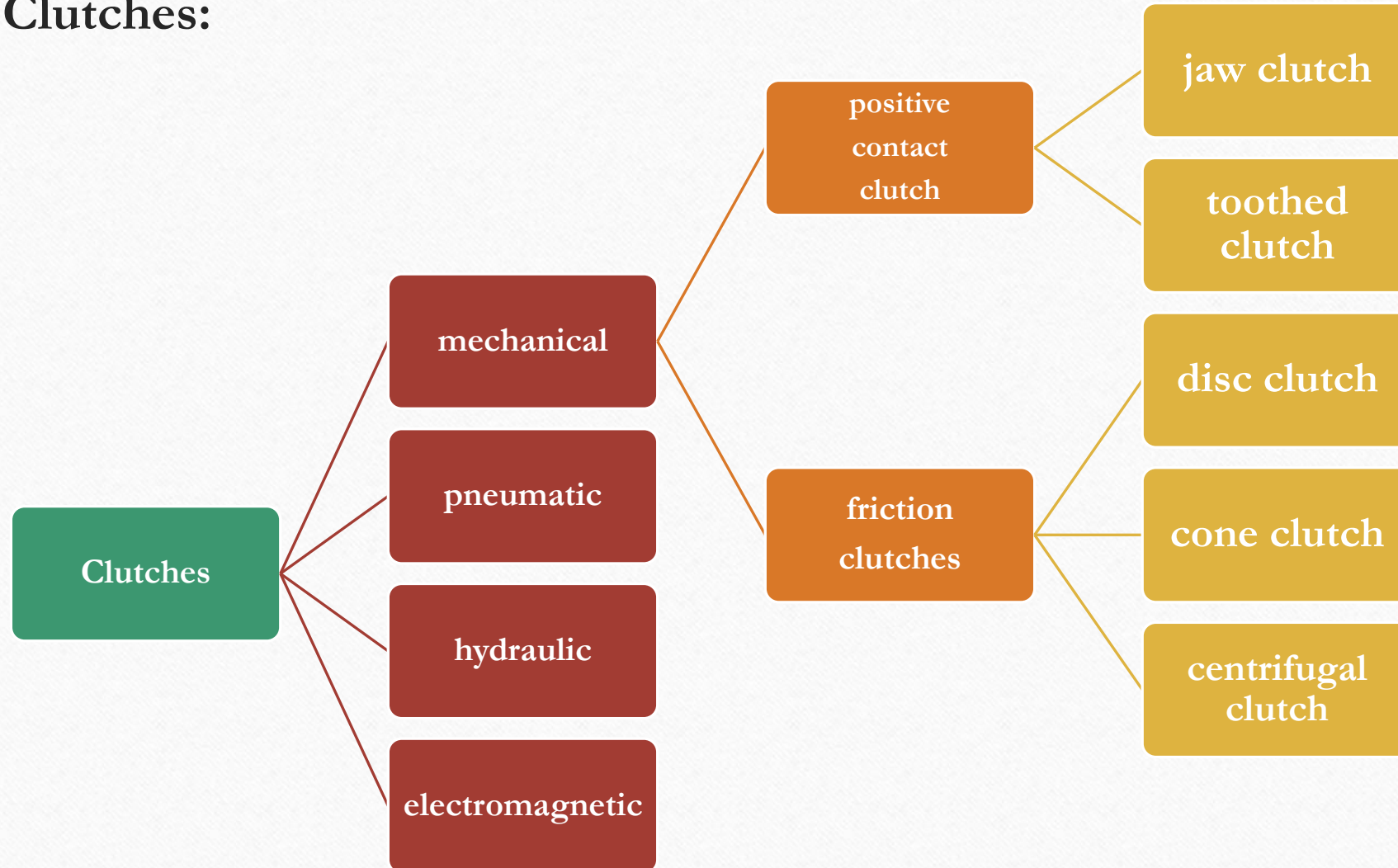



## ❖ Positive contact clutches

➤ *Transmit power from the driving shaft to the driven shaft by means of*

- *jaws or teeth*

- + Transmit large torque with no slip

- + Develop very little heat, because they do not depend upon friction.

- + Generally lighter.

- + Less costly than a friction clutches of similar torque capacity.

- -Can not be engaged at high speeds, max 60 rpm for jaw clutches, and 300 rpm for toothed clutches

- -Shock accompanies engagement at any speed

- -Require some relative motion in order to engage when both driving and driven shafts are at rest



Positive clutch in engage position

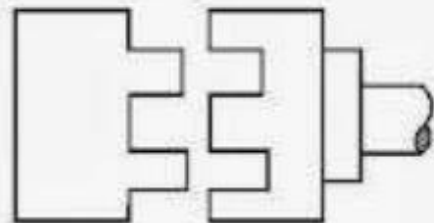

Positive clutch in disengage position



Square Jaw Clutch



SPIRAL JAW CLUTCH

## ❖ Friction clutches

➤ *Transmit power from the driving shaft to the driven shaft by means of*

- *plates, disks or cones*

- + Because they can slip relative to each other, there is very little shock during engagement.

- + Can be used for high speed engagement applications.

- -Do slip

- -Do wear out (requiring replacement of friction material)

- -Heat is developed (might require external cooling)



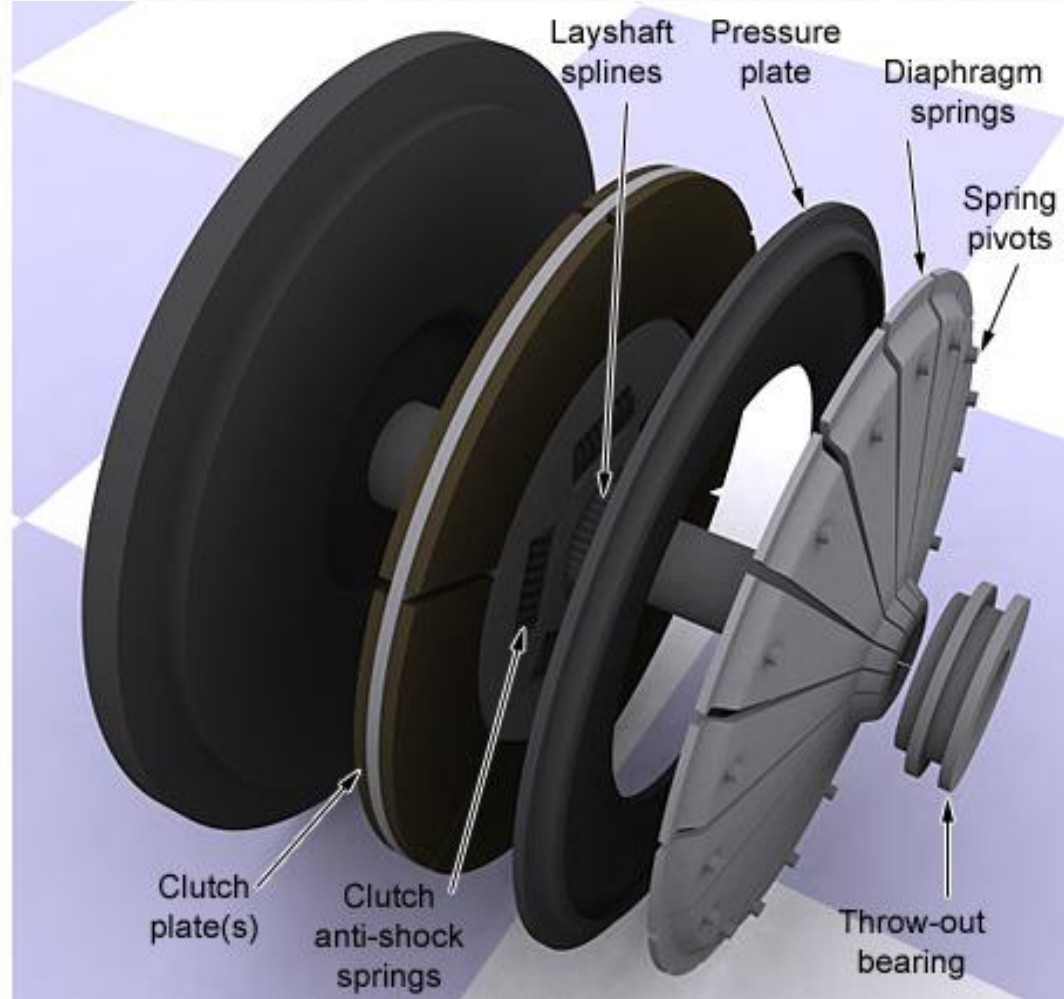
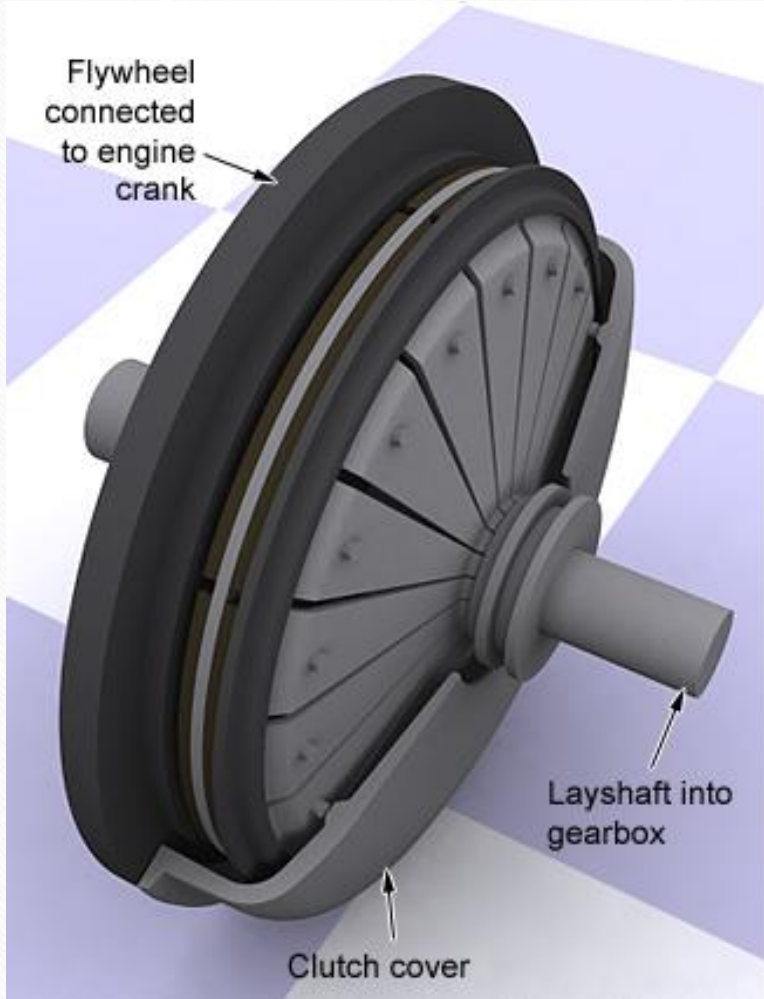

## ❖ Requirements of the clutch :

1. Torque transmission – Low/High
2. Clutch engagement – Gradual/Sudden
3. Heat dissipation – High/Low
4. Dynamic balancing – High/Low
5. Vibration damping – High/Low
6. Inertia – High/Low
7. Size- Big/Small
8. Operation- Easy/difficult

## ❖ Torque capacity of the clutch depends on :

1. Coefficient of friction- High/Low
2. The diameter of the driven plate – Big/Small
3. Spring thrust applied by the pressure plate- High/Low



## ❖ Limitations of capacity :

1. Max available  $\mu$  is 0.35, higher than these clutch becomes unstable
2. Increasing diameter increases its inertia & it will continue to spin after disengagement
3. There is a limit to clamping pressure to which friction lining material subjected if it is to maintain friction properties over a long period of time.



## ❖ Torque Transmitted by the clutch :

Torque transmitted  $T = n * F * R$

$F$  –frictional force =  $\mu * P$

$\mu$  - coefficient of friction

$P$  –Axial load

$n$  –number of plates

$R$  –effective mean radius of frictional surface

- -Torque transmitted depends on the radius of the friction material.
- -A limit on the spring force is set by the magnitude of the effort a driver may be expected to exert on a clutch pedal .
- - $\mu$  is constant for a given material .
- - $n$  can be increased to transmit more torque.

## ❖ Clutch

### ➤ Types of Clutches :

1. Single plate clutch
2. Multiple plate clutch
3. Cone clutch
4. Diaphragm clutch
5. Semi-centrifugal clutch
6. Centrifugal clutch

### ➤ Method of clutch actuation :

1. Mechanical
2. Hydraulic
3. Vacuum
4. Electro magnetic



## Components of the clutch

Flywheel      Friction plates      Pressure plate      cover



Throw-out bearing

Release fork

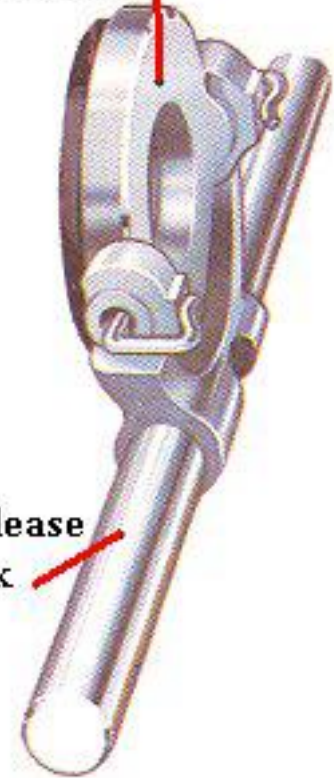



## ❖ Single plate clutch

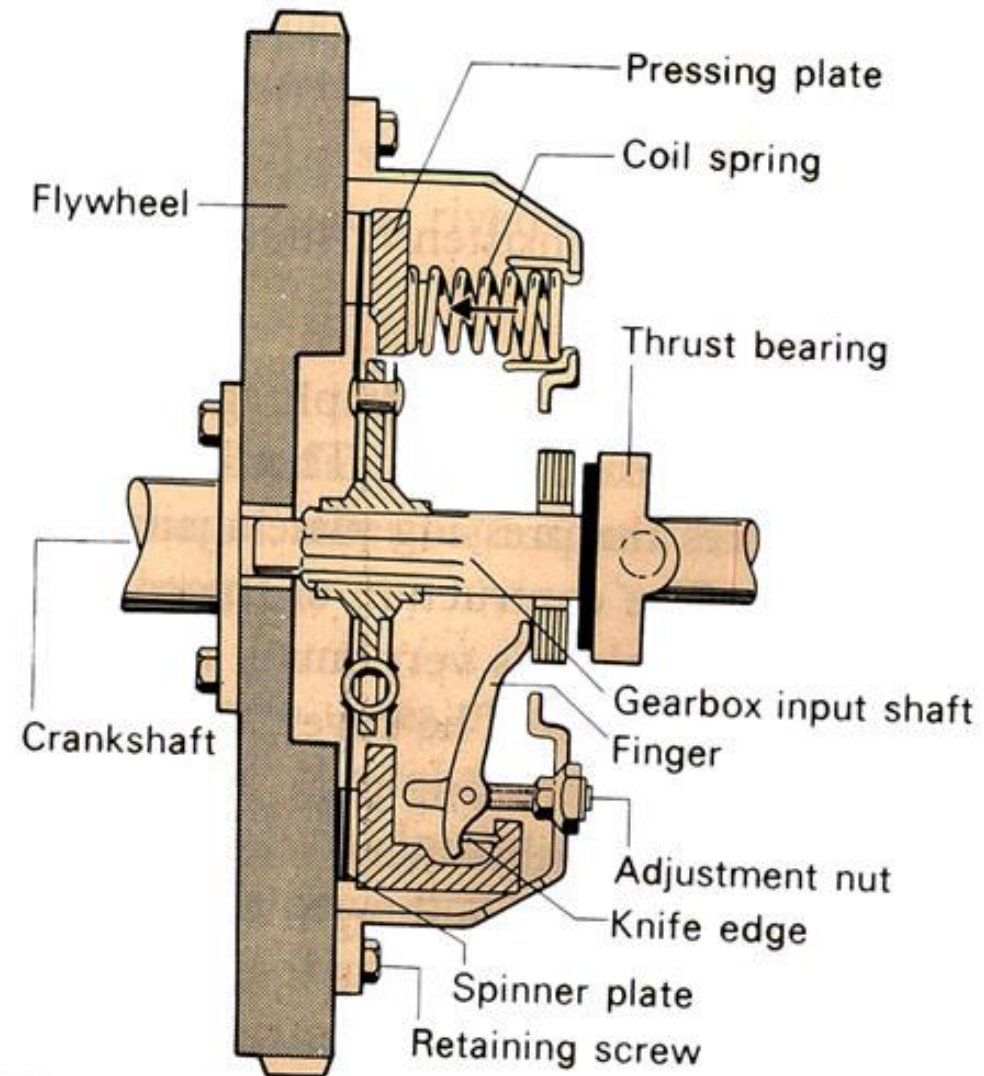
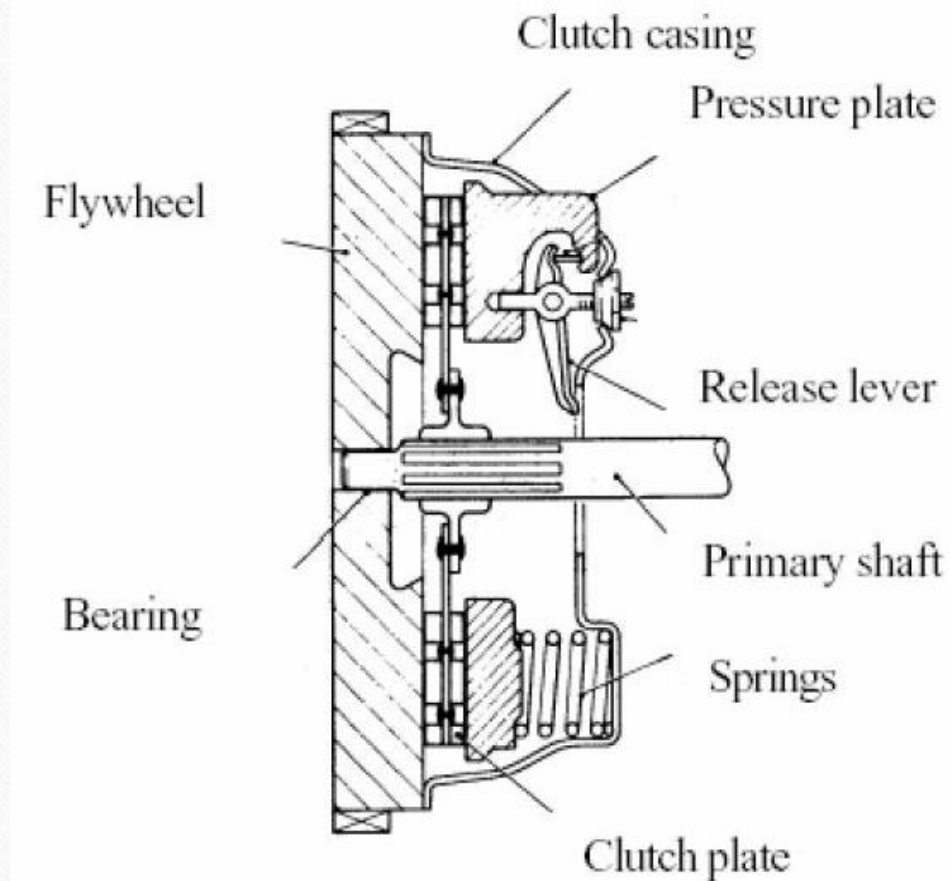



# 1. Coil Spring Clutch

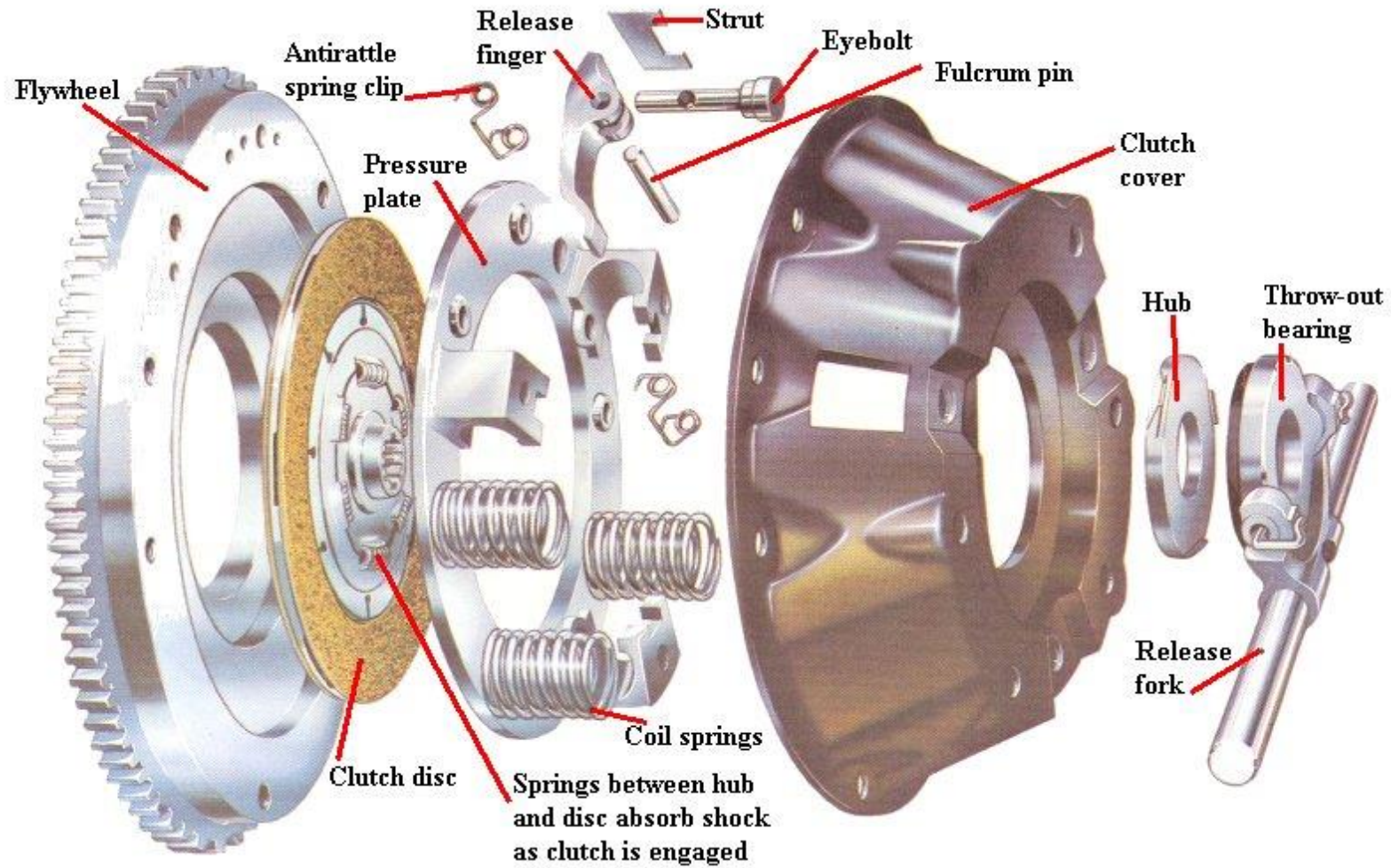



## ❖ Working of the clutch

- When the pressure is applied to the foot pedal, the pressure is transmitted through the release finger, fork and release bearing. Then the springs are compressed and it moves back the pressure disc thus releasing the clutch plate. Now the clutch is said to be disengaged.
- At this stage the pressure plate and flywheel are free to rotate with the clutch plate stationary.
- Similarly, when the clutch pedal is released, spring pressure is fully applied on the clutch plate. The plate is held between the flywheel and the pressure plate and rotates as a single unit.
- Typical friction disc travels about 0.06 inch (1.5 mm).
- Sometimes a clutch with greater holding power is needed. When limited space prevents making the clutch larger, a clutch with two friction discs can be used.
- Use of second disc adds area, thereby providing greater torque carrying capacity (used in medium and heavy trucks).



## Diaphragm clutch

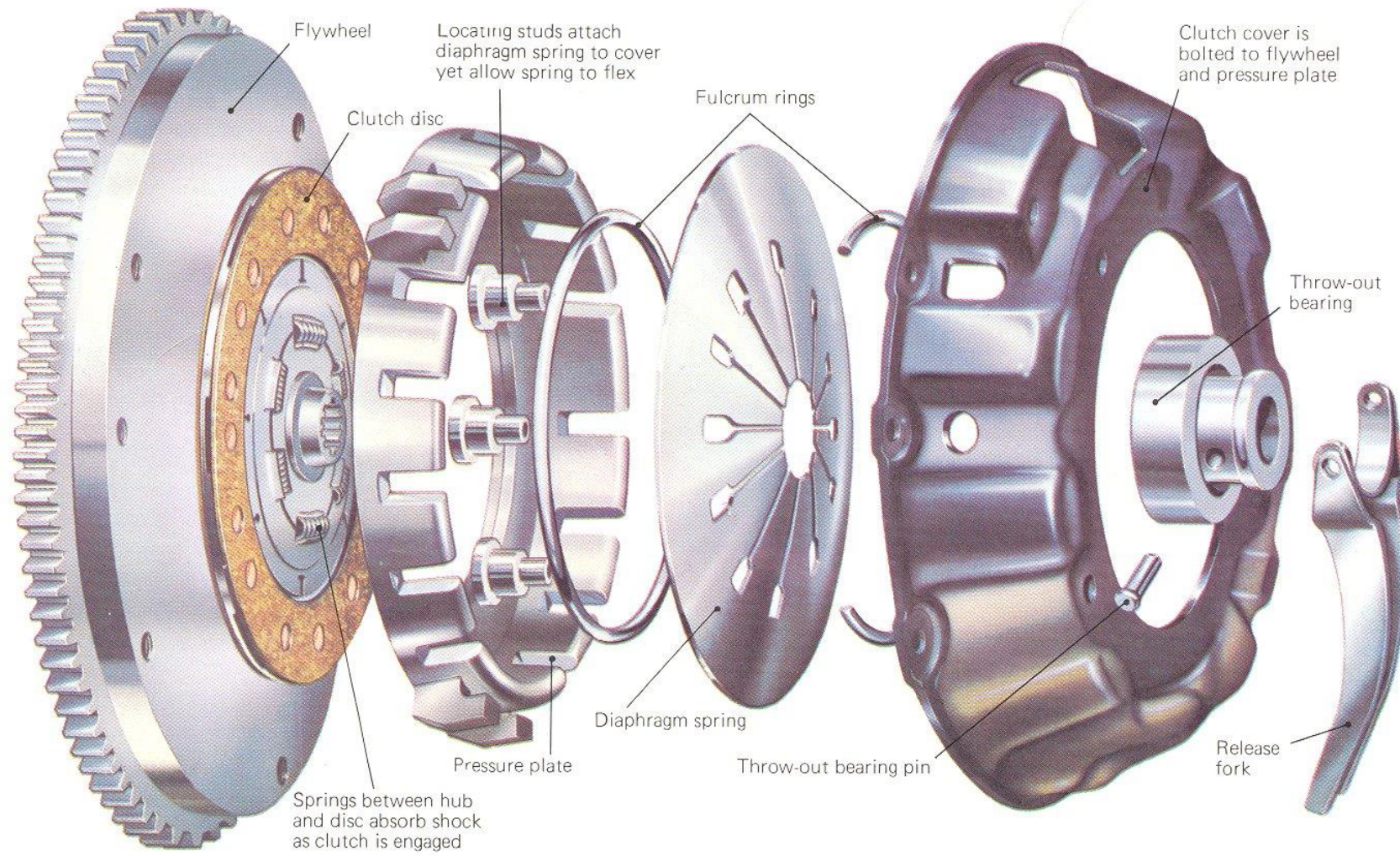



# Diaphragm Clutch

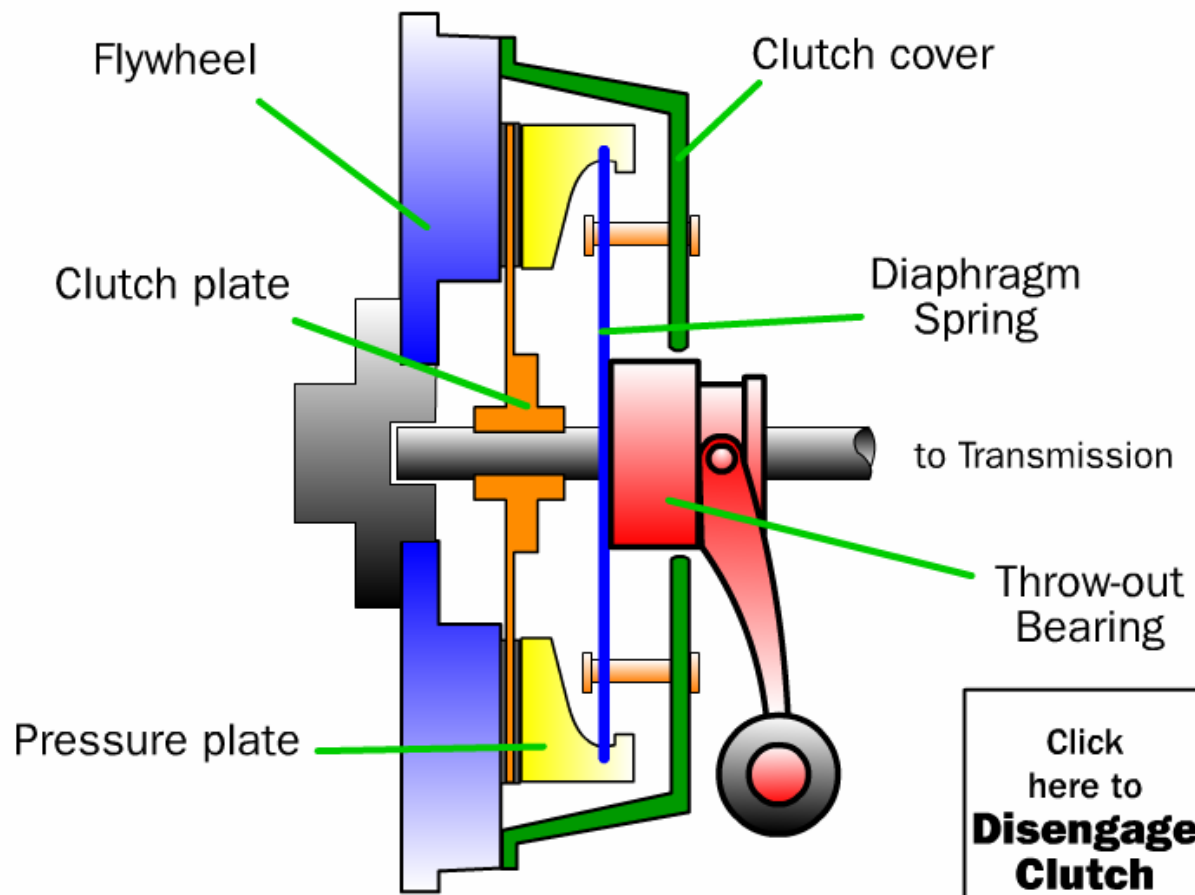

Click here to **Disengage Clutch**

- **Working of Diaphragm spring clutch**

- Used with most manual transaxles and in many rear manual wheel drive vehicles.
- A beleville(diaphragm) spring supplies the force that holds (the friction disc against the flywheel.
- The spring has tapered fingers pointing inwards from a solid ring. These act as release levers to take up the spring action as the clutch disengages.
- As the clutch pedal is pressed, the release bearing pushes against the fingers, which cause the diaphragm to pivot about the inner pivot ring, and outer section moves outwards, and pushes the pressure plates away from friction disc.
- Spring force varies according to the size and thickness of diaphragm spring.



### ❖ Merits of the Diaphragm Spring over Multi-coil Spring.

- (a) The diaphragm spring is compact permitting the use of a shallow clutch bell-housing to enclose the clutch unit.
- (b) Due to fewer moving parts squeaks, rattles, and wear are eliminated in diaphragm spring.
- (c) This system does not require initial adjustment of the pressure-plate unit unlike the multi-coil spring clutch units, where a small clearance is necessary between the release-lever plate and the thrust bearing.
- (d) In this design accurate balance of the clutch assembly is maintained under all operating conditions.
- (e) The diaphragm acts as both clamping spring and release-finger.
- (f) As the driven-plate wears, the spring axial load self-compensates in this clutch.
- (g) Clamping load in diaphragm-spring is independent of the engine speed whereas coil springs tend to bend along their length and lose their thrust at high speeds.
- (h) In this clutch disengagement pressures reduce with increase in pedal movement.

## ❖ Multi-plate Clutch:

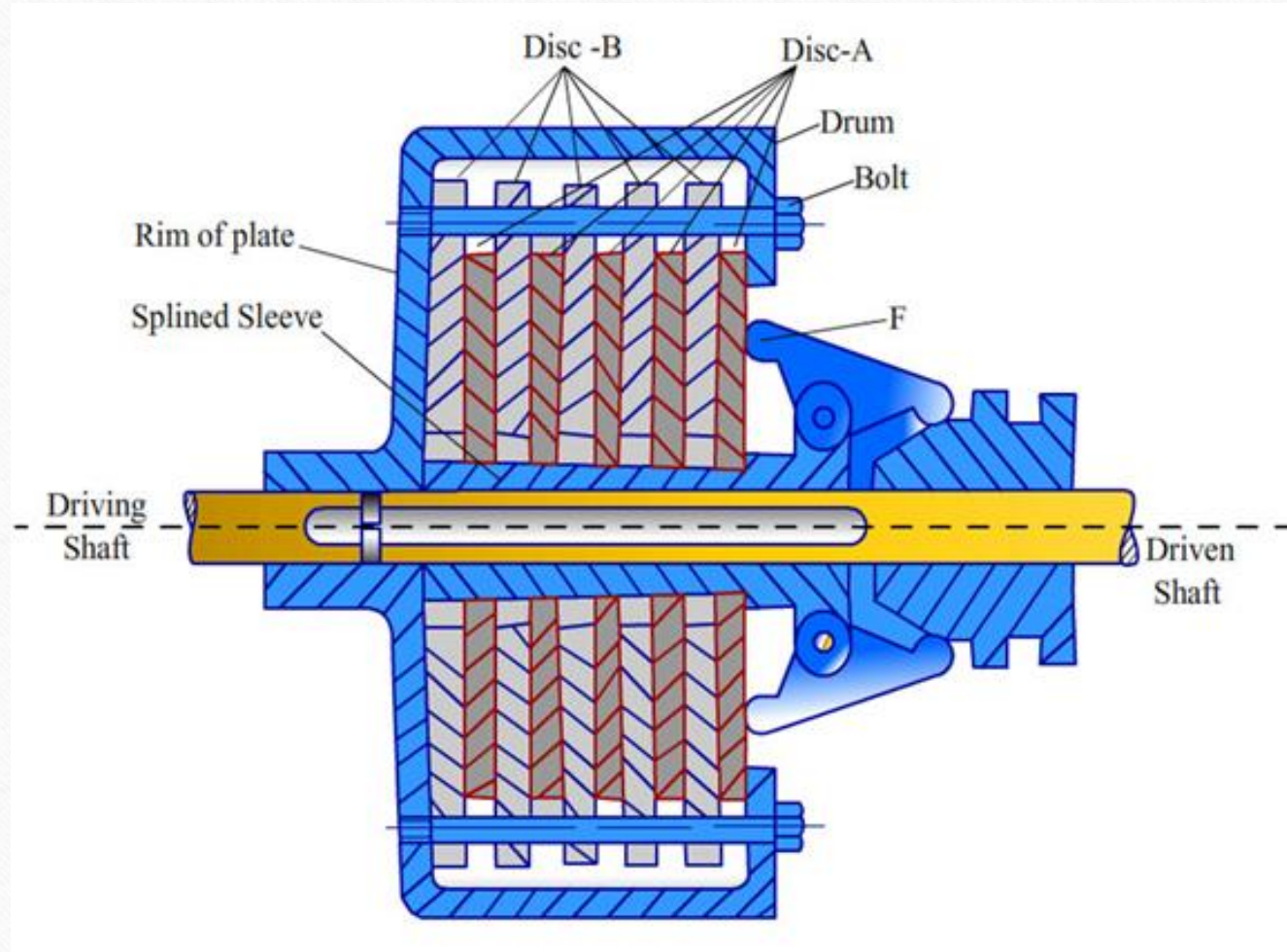



# Multi-plate clutch

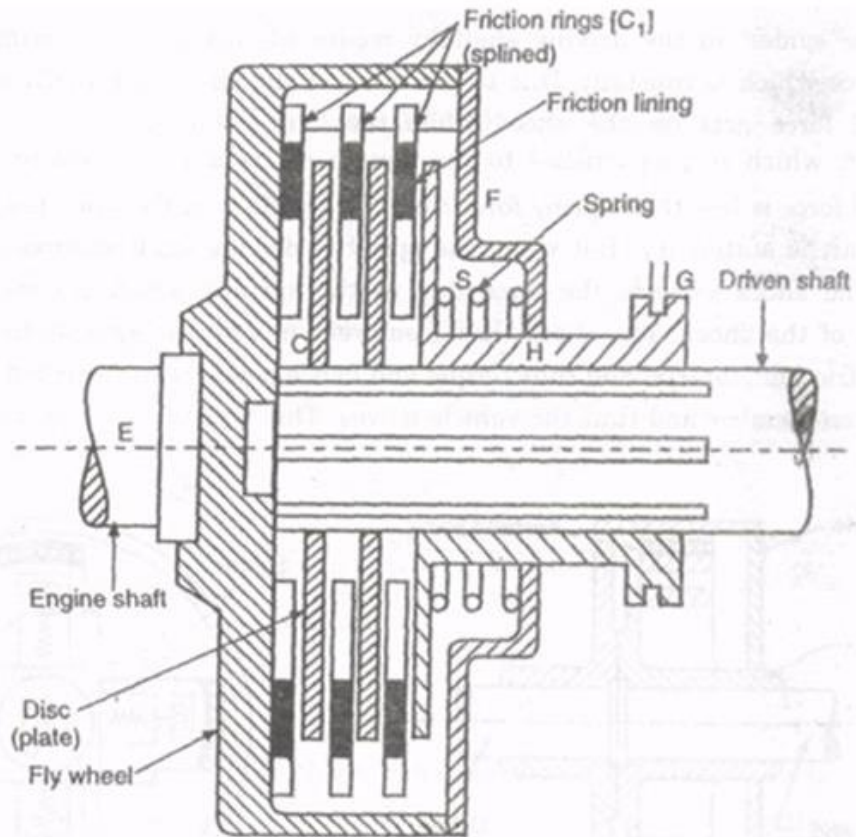

Fig. 6.31 : Multiple Plate Clutch

## ❖ Multi-Plate Clutch

- Multi-plate clutch consists of a number of clutch plates, instead of only one clutch plate as in the case of single plate clutch.
- As the number of clutch plates are increased, the friction surface also increase.
- The increased number of friction surfaces obviously increases the capacity of the clutch to transmit torque.
- The plates are alternately fitted to the engine shaft and the gear box shaft.
- They are firmly pressed by strong coil spring and assembled in a drum. Each of the alternate plate slides in grooves on the flywheel and the other slides on splines on the pressure plate.
- Thus, each alternate plate has inner and outer splines.



- The multiple clutch works in the same way as the single plate clutch, by operating the clutch pedal.
- The multiplate clutches are used in heavy commercial vehicles, racing cars and motor cycles for transmitting high torque.
- The multiple clutches may be dry or wet.
- When the clutch is operated in an oil bath, it is called a wet clutch.
- When the clutch is operated dry, it is called dry clutch.
- The wet clutch are generally used in conjunction with, or as a part of the automatic transmission.
- It is used in racing cars and heavy motor vehicles which have high engine power.

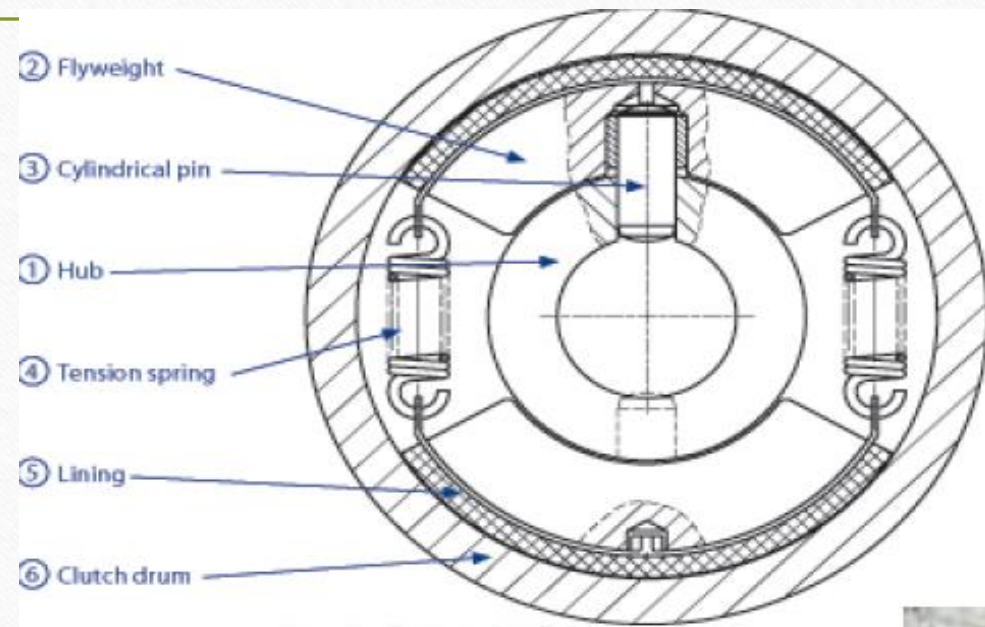



# Cone Clutch:

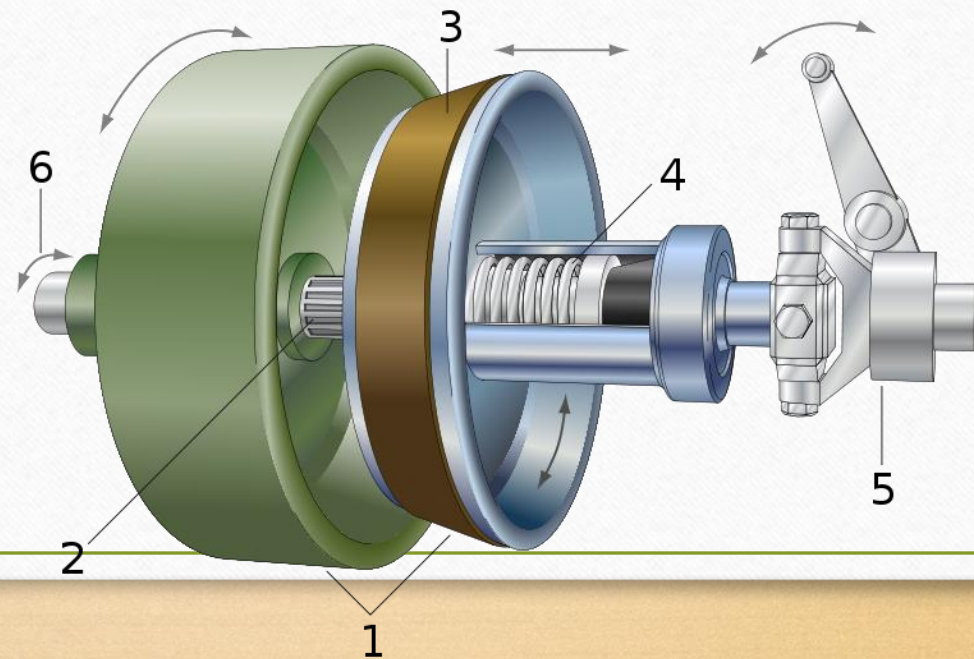
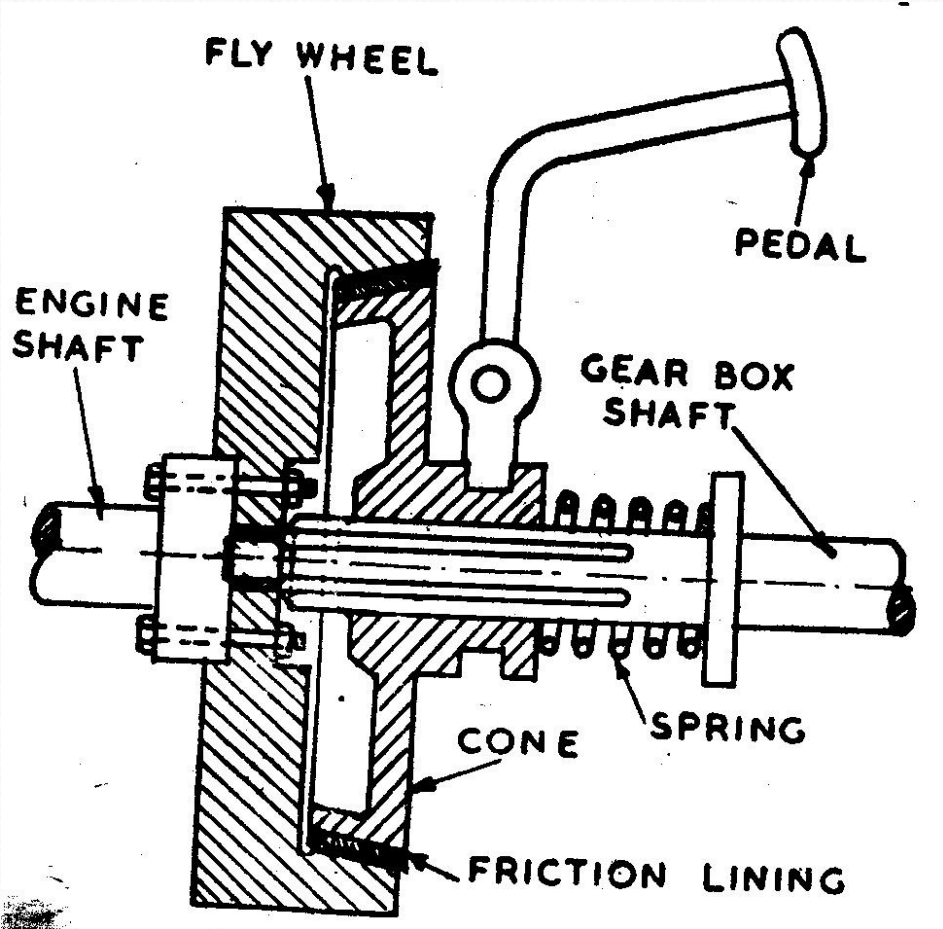

## • **Cone Clutch:**

• They are wedge clutch provides a positive drive when the external face of the male cone member engages with the internal face of recessed conical member.

• The facing is usually fitted to the female or recessed member in order to improve heat dissipation and durability.

• Normally cone clutch are used with **epicyclic gear** trains for a higher torque transmission.

• The energy which a cone clutch can absorb during on engagement is less compared to the energy absorbed by a multiple clutch.

• But it is compact, cheaper and requires low clamping load due to the wedging action. The cone clutches are loaded by spring or hydraulic cylinders.

• .



- **Wedge angle and accurate axial alignment** are the two important factors for good cone clutch performance.
- If the wedge angle is very less, it results in excessive wedge action and fierce engagement. This in turn results in difficult operation for disengagement.
- If the wedge angle is too large it reduces torque transmission capacity of the clutch and make the clutches to skid.
- **Semi-cone angle of 12-16** are commonly used for effective torque transmission.
- The torque transmitted by a cone clutch is given by,  
$$T = \mu W (r_1 + r_2) / 2 \sin \alpha$$
- Where,  $r_1$  and  $r_2$  are the radius of large and small cone (friction) in meters.
- $\alpha$  is the semi – cone angle.

## Electromagnetic Clutch:

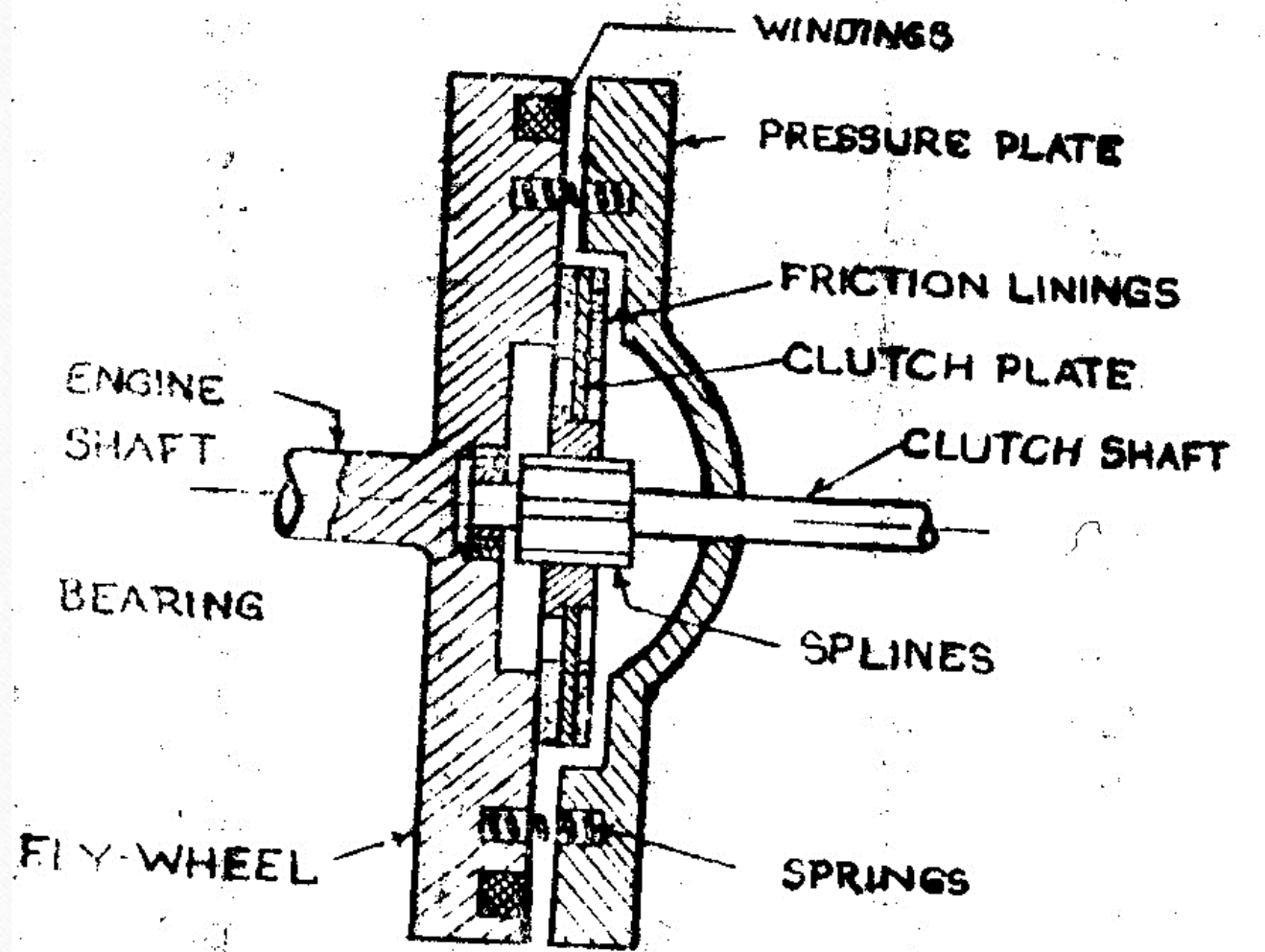



## • **Electromagnetic Clutch**

- In this system the clutch is controlled by means electric current supplied to the field windings in the flywheel.
- The fly wheel is attached with the field winding, which is given electric current by means of battery, dynamo or alternator.
- The construction feature of main components is almost similar to the single plate clutch.
- When electric current is supplied to the windings the flywheel will attract the pressure plate and clutch plate is forced between pressure plate and flywheel resulting in engagement.
- When the supply to the winding is cut off the clutch is disengaged by releasing the pressure plate due to the force exerted by the helical springs or tension springs.
- Electromagnetic clutch consists of a clutch release switch.
- When then driver holds the gear lever to change the gear, the switch is operated cutting off the current to the winding which causes the clutch disengaged.

- When the vehicle is stalling, the engine speed is lower & the dynamo output is low, the clutch is not firmly engaged. Therefore, three springs are also provided on the pressure plate which helps the clutch disengaged at low speed.
- The forces of the electromagnet can be regulated by means of an electrical resistance provided with acceleration system and controlled by the accelerator pedal.
- When the speed is increased, the accelerator pedal is pressed and the resistance is gradually cut off and thus in this way, force of electromagnet is increased and clutch transmission becomes more rigid.
- Slippage should occur only during acceleration. When the clutch is fully engaged, there is no relative slip (if the clutch is sized properly). Torque transfer is 100% efficient.



# Clutch Plate

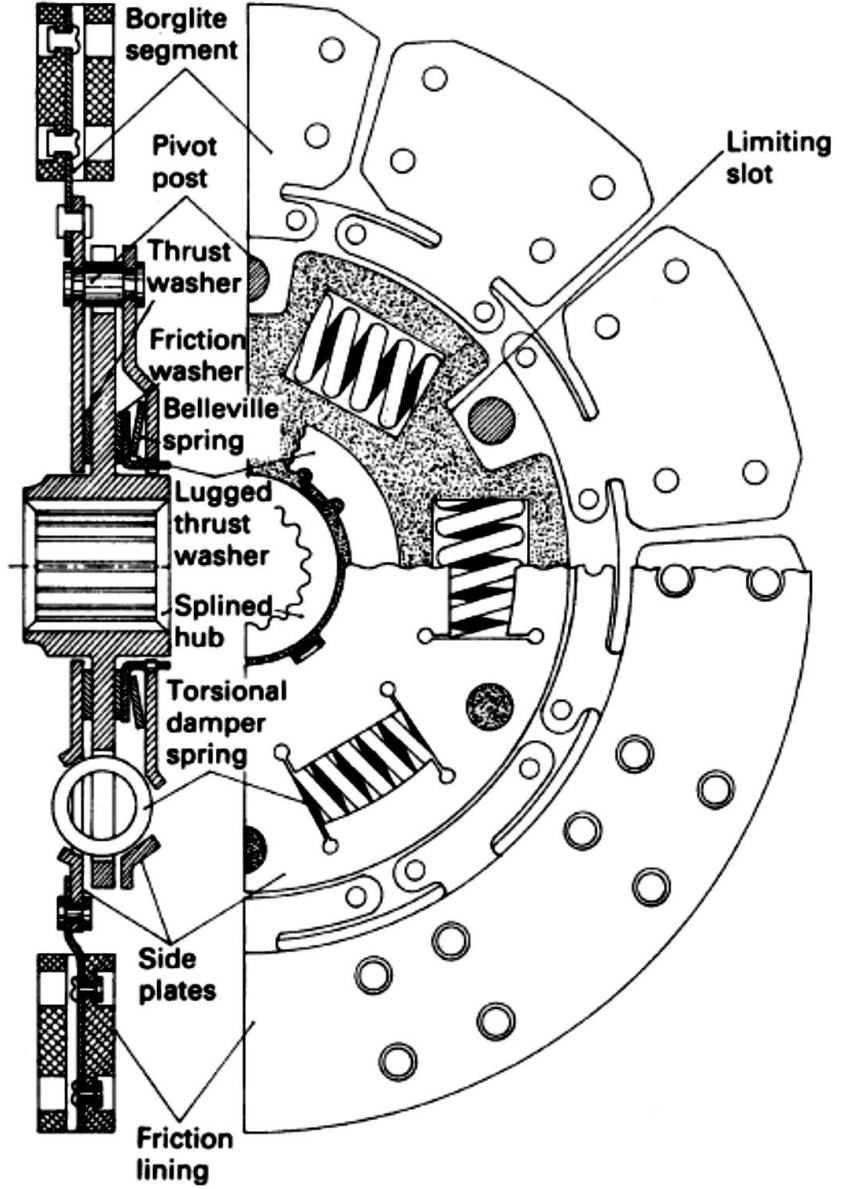
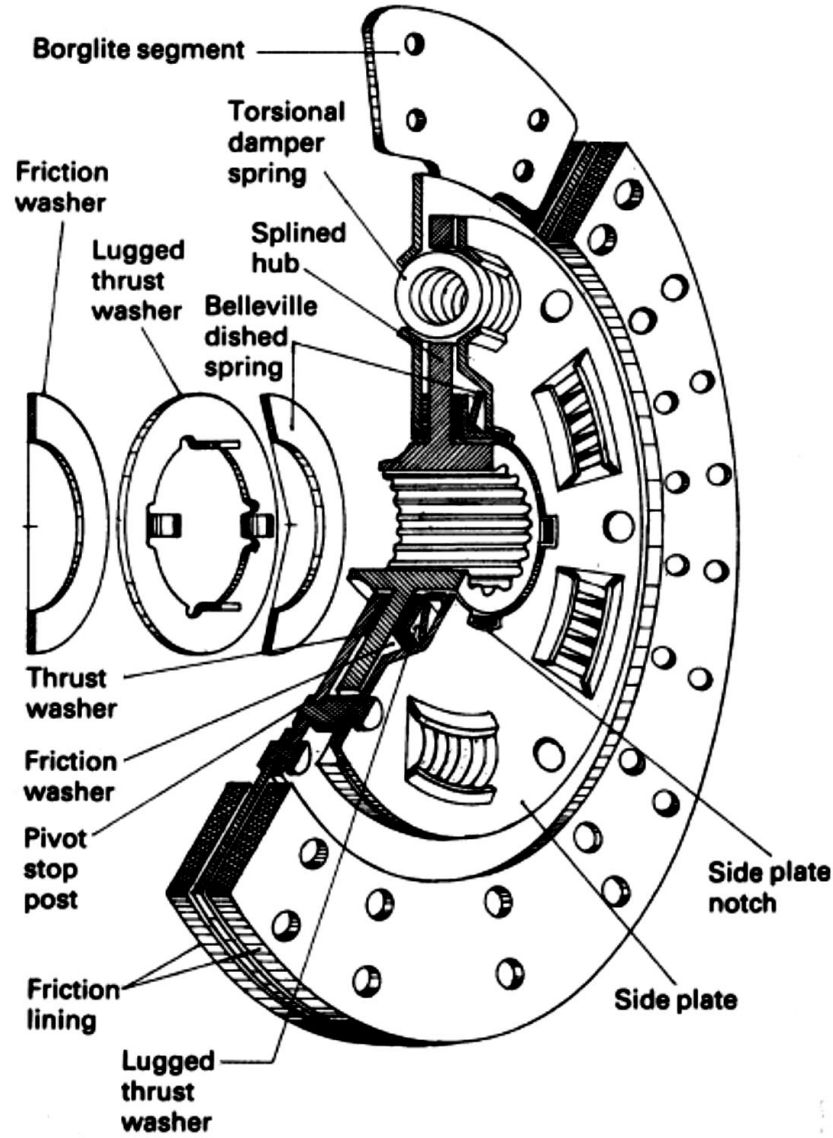

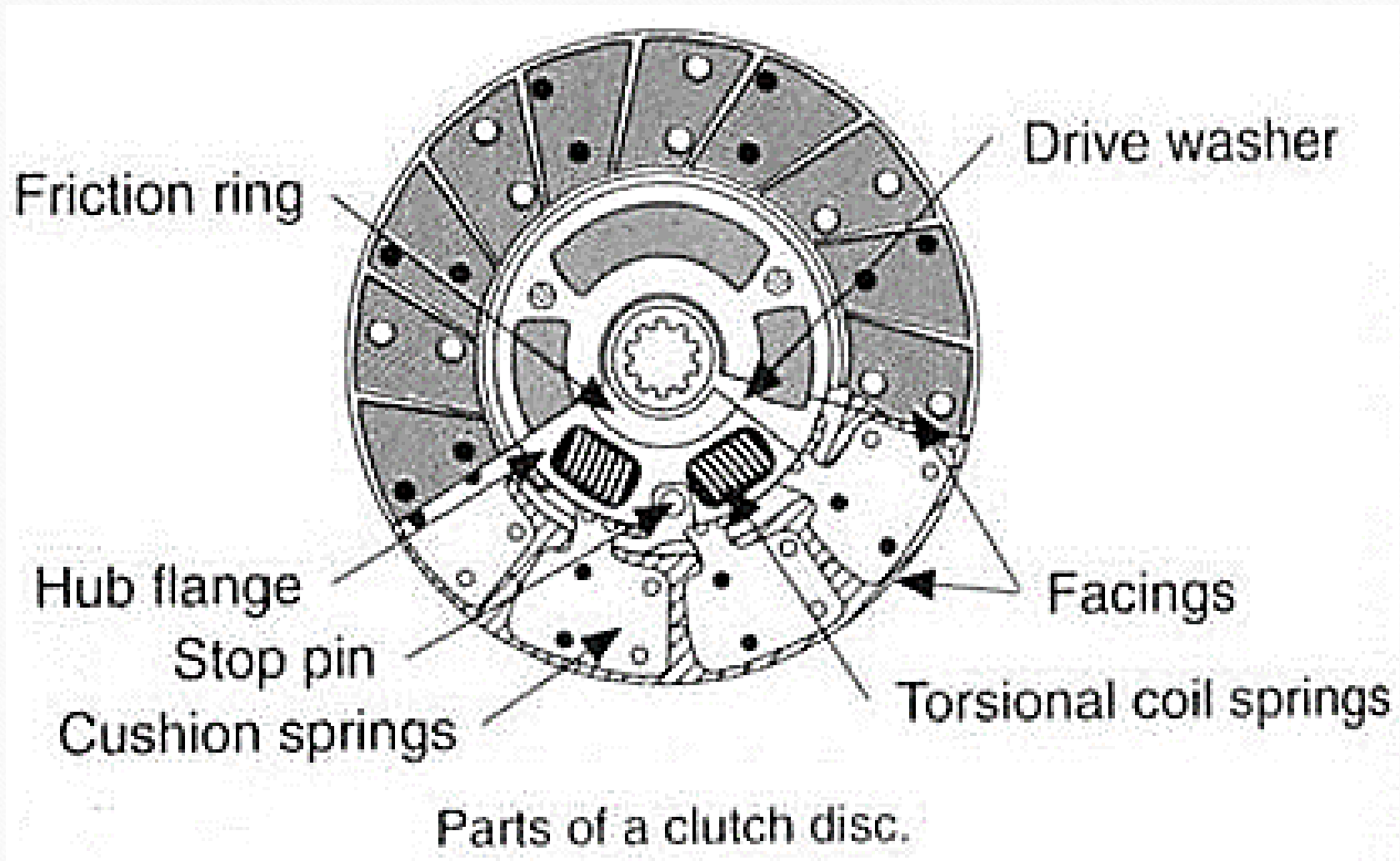



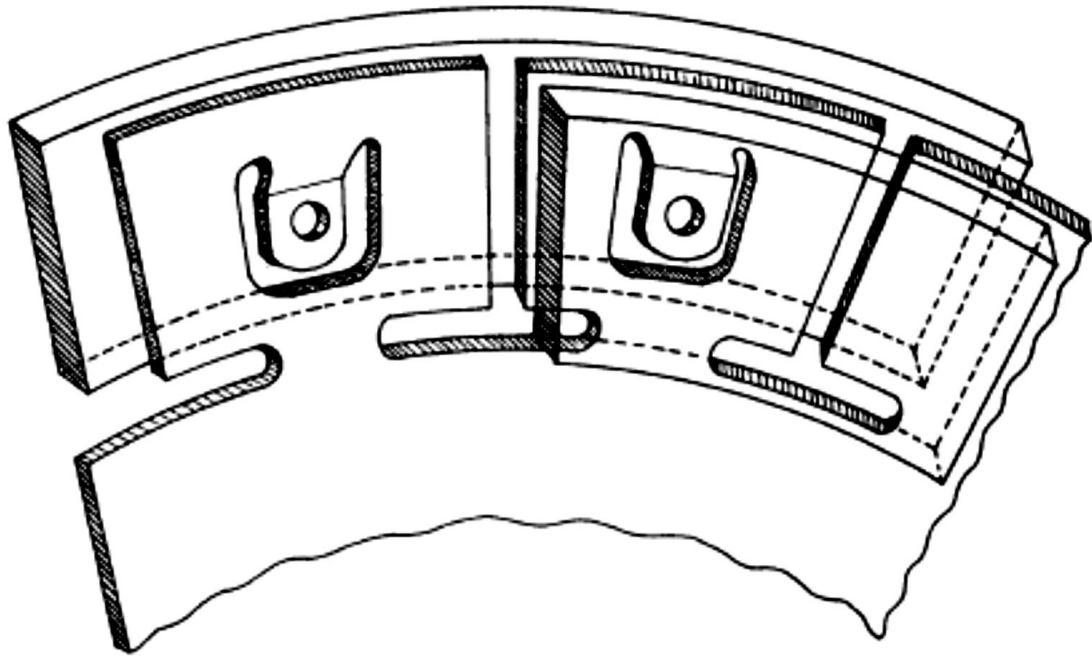

**(a) Arcuate horseshoe spring**

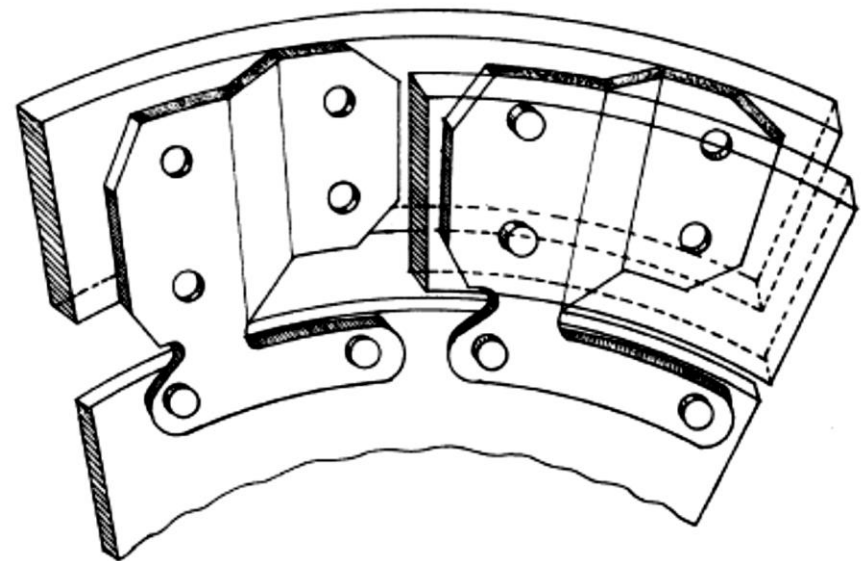

**(b) Borglite segment spring**

- Both forms of crimped steel spring segment situated between the friction linings provide progressive take up over the greater pedal travel and prevent snatch
- The separately attached spring segments are thinner than segments formed out of the single piece driven plate, because of that squeeze take up is generally softer and the spin inertia of the thinner segments is noticeably reduced.
- Ensures satisfactory bedding of the facing material and even distribution of the work load.
- Cooling between friction lining occurs when the clutch is disengaged which helps to regain the frictional properties of the facing material.
  - **Better clutch engagement control.**
  - **Improved distribution of the friction work over the lining faces reduces the peak operating temperature.**



## ❖ DIVIDED PROPELLER SHAFTS

- Two-piece drive-lines, with two shafts and an intermediate support bearing are generally used on trucks with wheel bases from 3.4 to 4.8 m.
- The two-piece propeller shaft has three universal joints, and the primary propeller shaft is of the fixed-joints-and-tube-assembly type, but the secondary propeller shaft has a slip-joint at the support-bearing end to accommodate any elongation due to suspension movement. Usually the primary shaft is in line with the gearbox mainshaft axis, but the secondary propeller shaft is inclined slightly so that it intersects the rear-axle final-drive pinion shaft.



## ❖ DIVIDED PROPELLER SHAFTS

- For vehicles with wheelbases over 4.8 m, a three-piece drive-line with two intermediate support bearings may be necessary. There are four universal-joints, and it can be seen that the intermediate shaft lies parallel to the output shaft of the gearbox. Again only the rear propeller shaft incorporates a slip-joint to compensate for shaft length change.

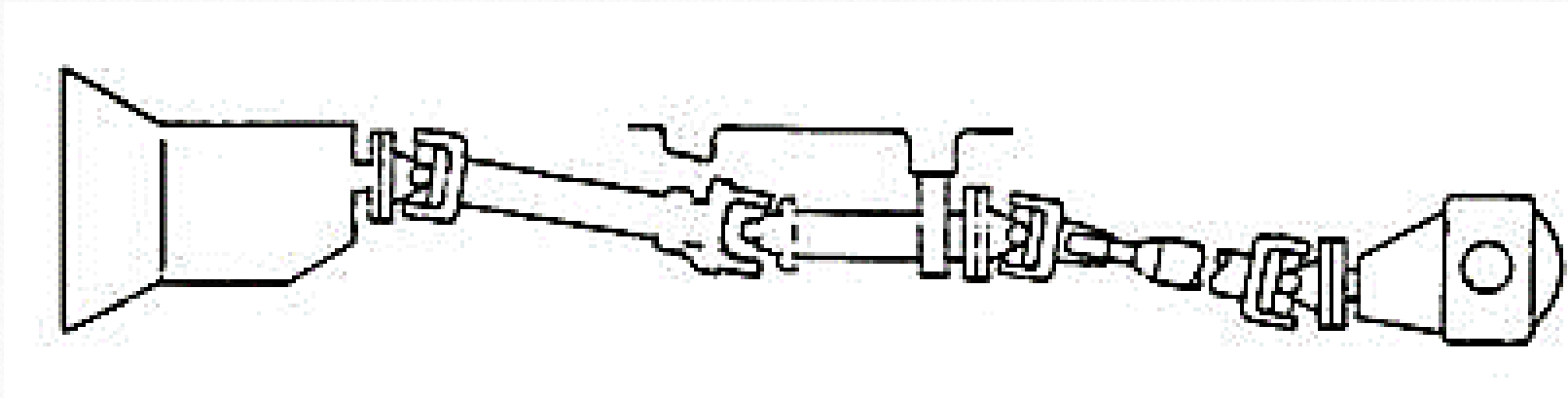



- **UNIVERSAL JOINTS:**

- The propeller shaft is provided with universal joints at its ends. The universal joint is a form of connection between two shafts, whose axes intersect and may assume different inclination at different times. This joint permit the rotation of one shaft about its axis by another shaft which rotates about its own axis.

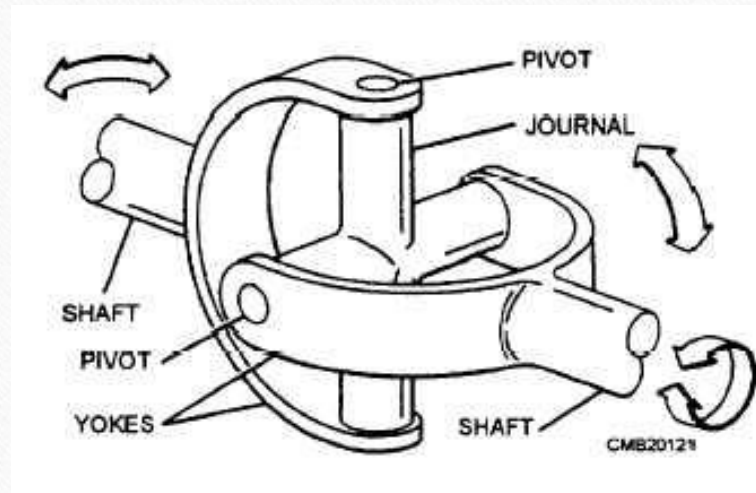
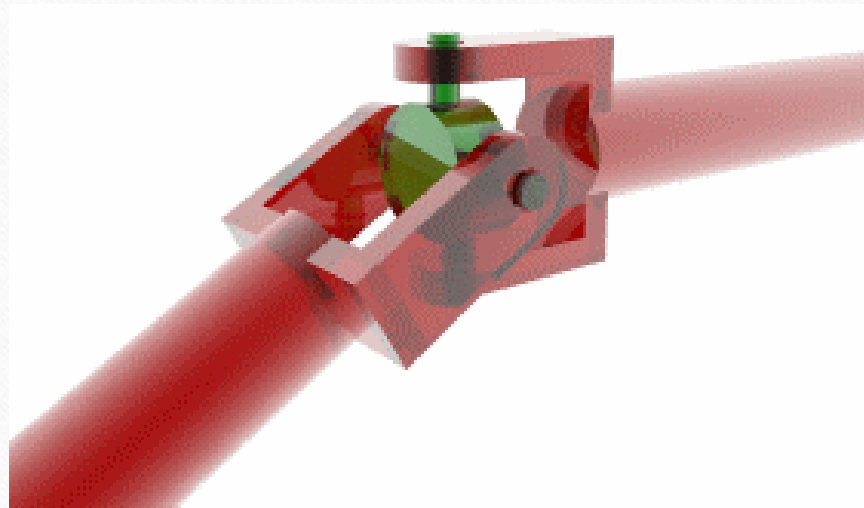

## ❖ CONSTANT VELOCITY UNIVERSAL JOINT

- Vehicles with front wheel drive require a special universal joint to maintain torque at the wheel whilst turning a corner. The joint is called a constant velocity joint.
- This joint does not have the disadvantage of the Hooke's type joint where two joints are necessary to maintain uniform velocity.
- In this joint a mechanism is incorporated between the “yokes” which automatically align itself when the angle is formed by the two shafts.
- The alignment may be obtained through the
- movement of steel balls in grooves or through
- the deflection of rubber components –
- these deflections neutralising the velocity
- variation.

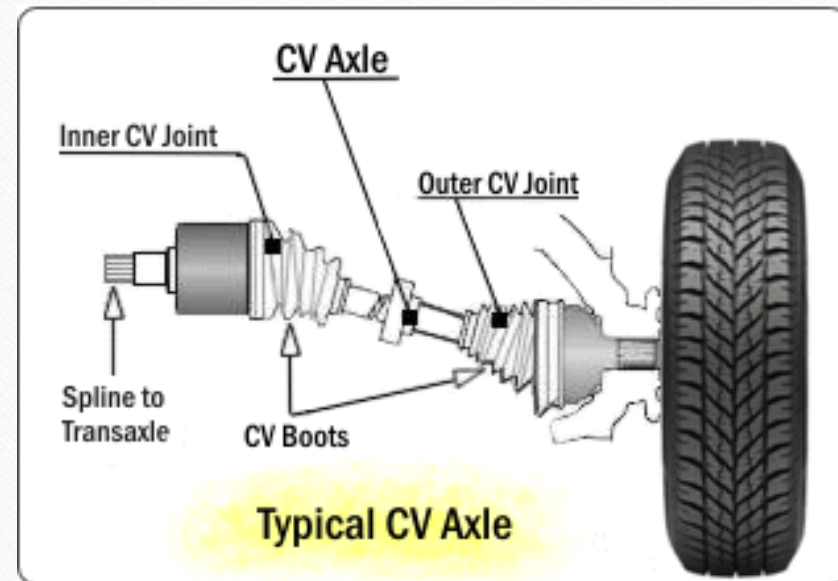



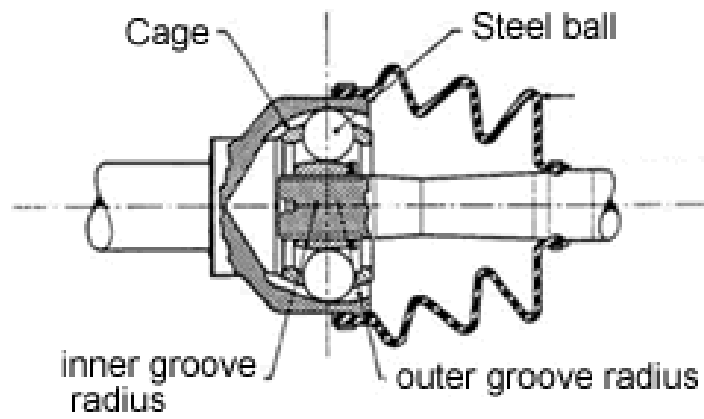

**Birfield c.v. joint**

Fifth ball at centre acts as a pivot for the two forks

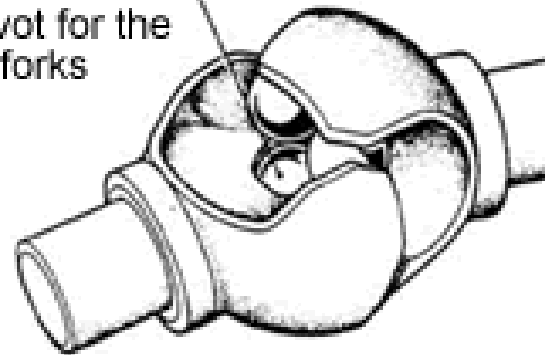

**Weiss c.v. joint**

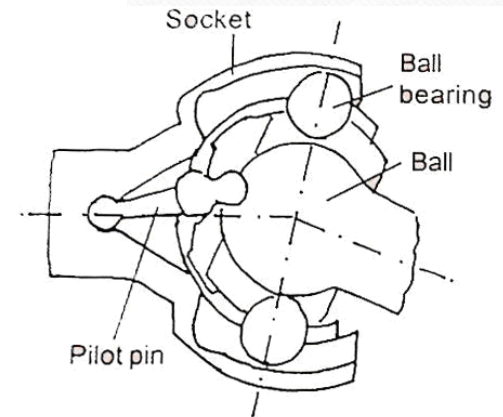

**RZEPPA COSTANT-VELOCITY JOINT**

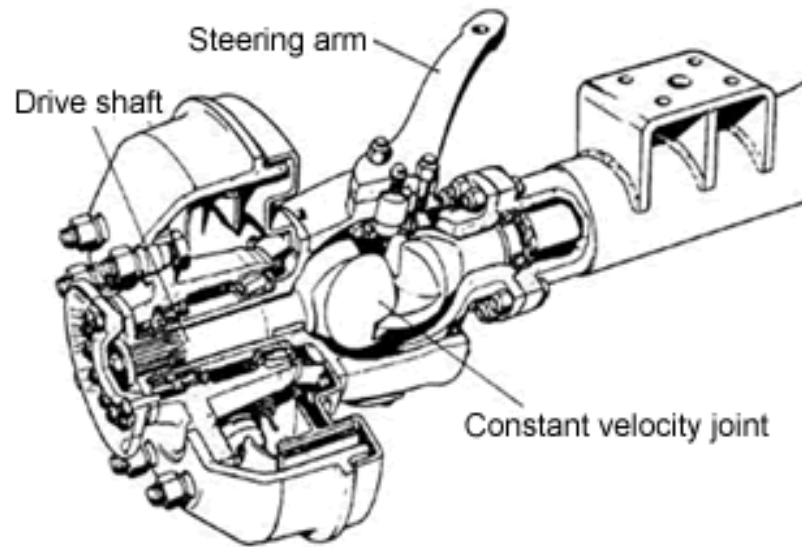

- The constant velocity universal joint does not suffer from the variation in the speed of the driven shaft. The speeds of the shafts connected by this joint are absolutely equal.
- A constant velocity universal joint consists of two yokes with oval races, four driving balls, a centre ball, a centre ball pin and retainer pin. The driving balls are freely mounted in the grooves. The centre ball is secured on the pin in one of the yokes. In this unit, the balls are the driving contact. They move laterally as the joint rotates.
- The movement of the balls permits the point of the driving contact between the two halves of the coupling to remain in a place which bisects the angle between the two shafts.
- By this arrangement, the fluctuation in speed of the driven shaft is avoided.



• Tripod CV Joint:

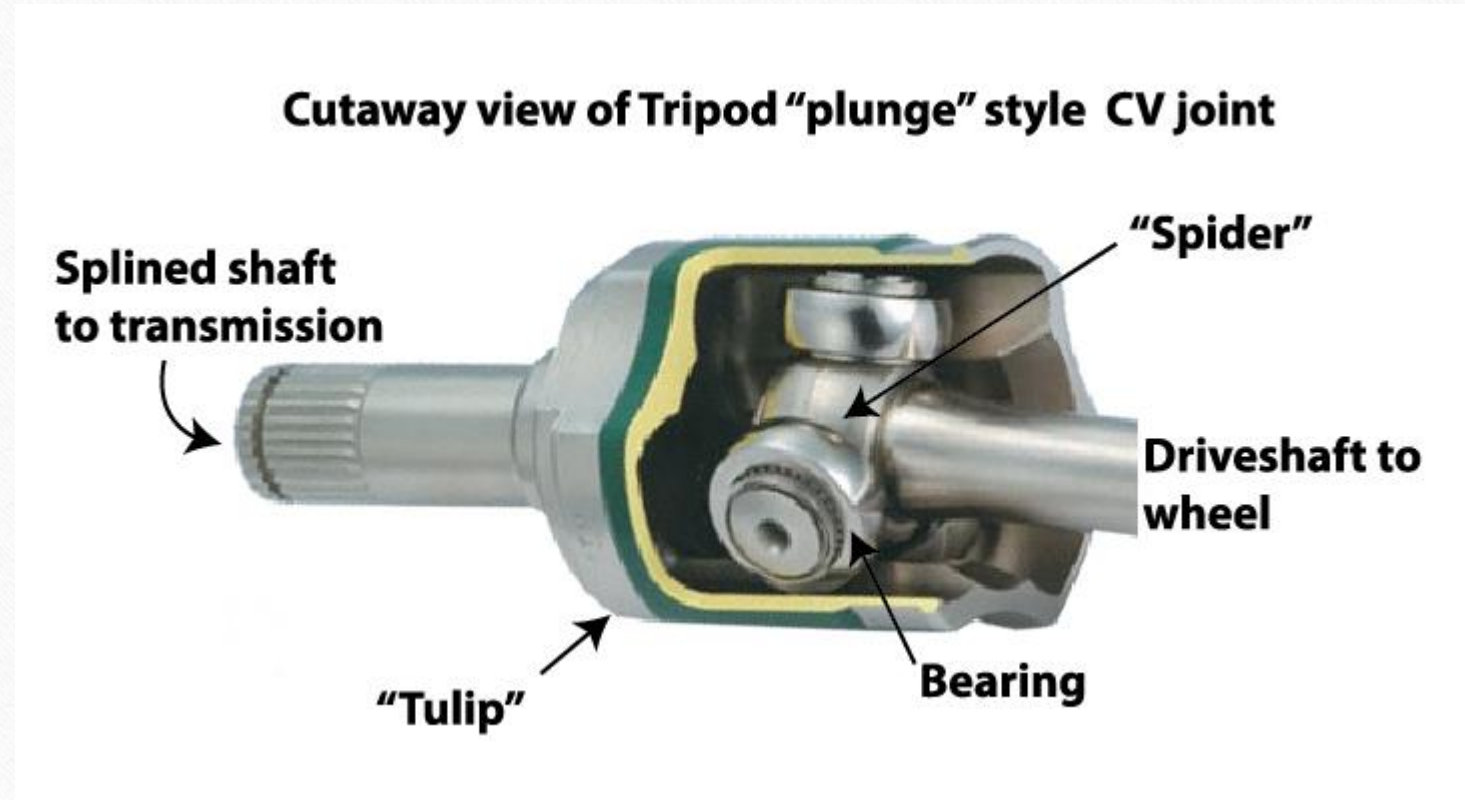

## Spider Construction:

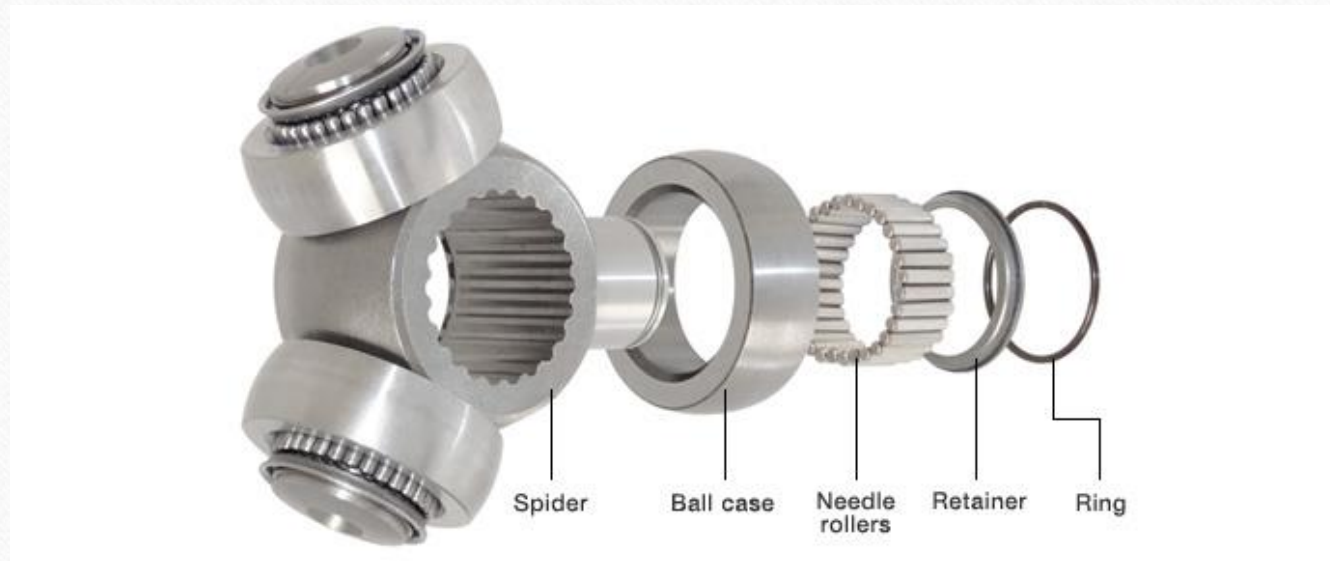



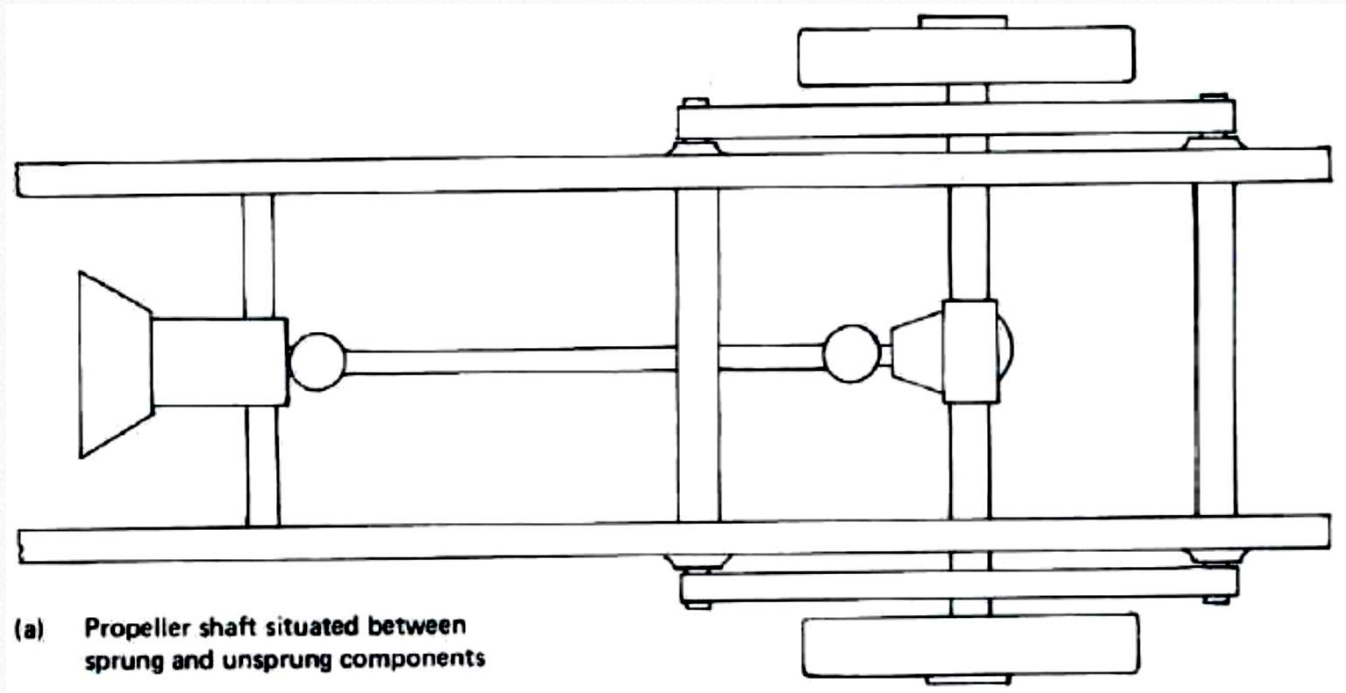

(a) Propeller shaft situated between sprung and unsprung components

- The suspension springs are bolted rigidly to the rear axle casing. The front ends of the springs are pivoted on pins.
- These pins are carried in brackets bolted to the vehicle frame. The rear ends of the springs are connected to the frame by swinging links or shackles.
- This arrangement permits the deflection of the spring when the vehicle is accelerated or braked.
- The propeller shaft is provided with two universal joints one at each end and a sliding joint at one end. This arrangement permits the rear axle assembly to move up and down due to projections and depression on the road surface.



- Engine power is always transmitted from the gear box to the final drive in the differential through the propeller shaft. From the differential the driving torque is transmitted to the road wheels through the axle shafts. In this transmission system, the suspension springs also act as torque and thrust members.

# Safety Systems in Automotive

- **User safety** plays an important role in the automotive industry.
- **Some considerations to be look upon to save human lives while riding car or truck.**
  - In General Automobile Safety Systems are classified in to two segments :
    - Active Safety Systems : **To avoid Accidents**
    - Passive Safety Systems : **Control the Affects of Accidents**



# Active Safety Systems

- **Active Safety** Systems is the term which plays a “*preventive role in avoiding crashes and accidents*” by providing advance warning to the driver with additional assistance.
- Some of the Active Safety systems are –
  - Anti-Lock Braking Systems (ABS)
  - Electronic Stability Control (ESC)
  - Tire Pressure Monitoring System (TPMS)
  - Lane Departure Warning System (LDWS)
  - Adaptive Cruise Control (ACC)
  - Driver Monitoring System (DMS)
  - Blind Spot Detection (BSD)
  - Night Vision System (NVS)

# Passive Safety Systems

- **Passive driving safety** refers to systems in the car that protect the driver and passengers **from injury if an accident occurs**.
- Passive Safety Systems play a role in **limiting/containing the damage/injuries** caused to driver, passengers and pedestrians in the event of a crash/accident.

Some of Passive Safety Systems are –

Airbags, Seatbelts, Pedestrian safety system, Occupant Sensing System etc.



# What are seatbelts?



- > Mandatory safety feature provided for each seat in the vehicle.
- > Secures passengers by crossing their chest/waist with a material belt that fastens into the side of the seat.
- > Other safety features such as airbags and head restraints are more effective if the occupant is wearing their seatbelt.

# Importance of seatbelts

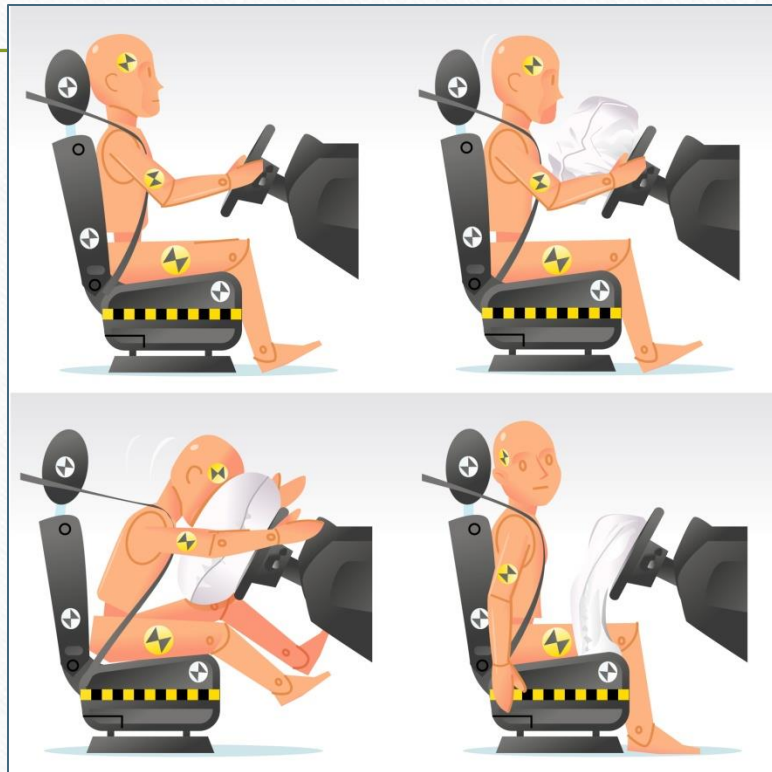

- > Seatbelts reduce risk of serious injury to the head, chest and extremities by 50%-83%.
- > Even with more sophisticated safety features, seatbelts are still considered the most important.



# Importance of seatbelts

---

- > Seatbelts reduce the movement of occupants inside the vehicle during a crash.
  - » Body's contact with other objects in the vehicle (steering wheel, dashboard) is minimized.
  - » Prevents passengers from becoming projectiles in a crash and potentially killing other occupants.
- > Prevents occupants from being thrown out of the vehicle.
  - » 3/4 of occupants ejected from a vehicle will die.

# Introduction to Anti-lock Braking System

---

- Anti-lock braking system (ABS) is a safety anti-skid braking system used on aircraft and on land vehicles, such as cars, motorcycles, trucks and buses
- Anti-lock braking system (ABS) is an automobile safety system prevent the wheels of a vehicle locking as brake pedal pressure is applied, often suddenly in an emergency or short stopping distance.
- This enables the driver to have steering control, preventing skidding and loss of traction.



# Anti-lock Braking System

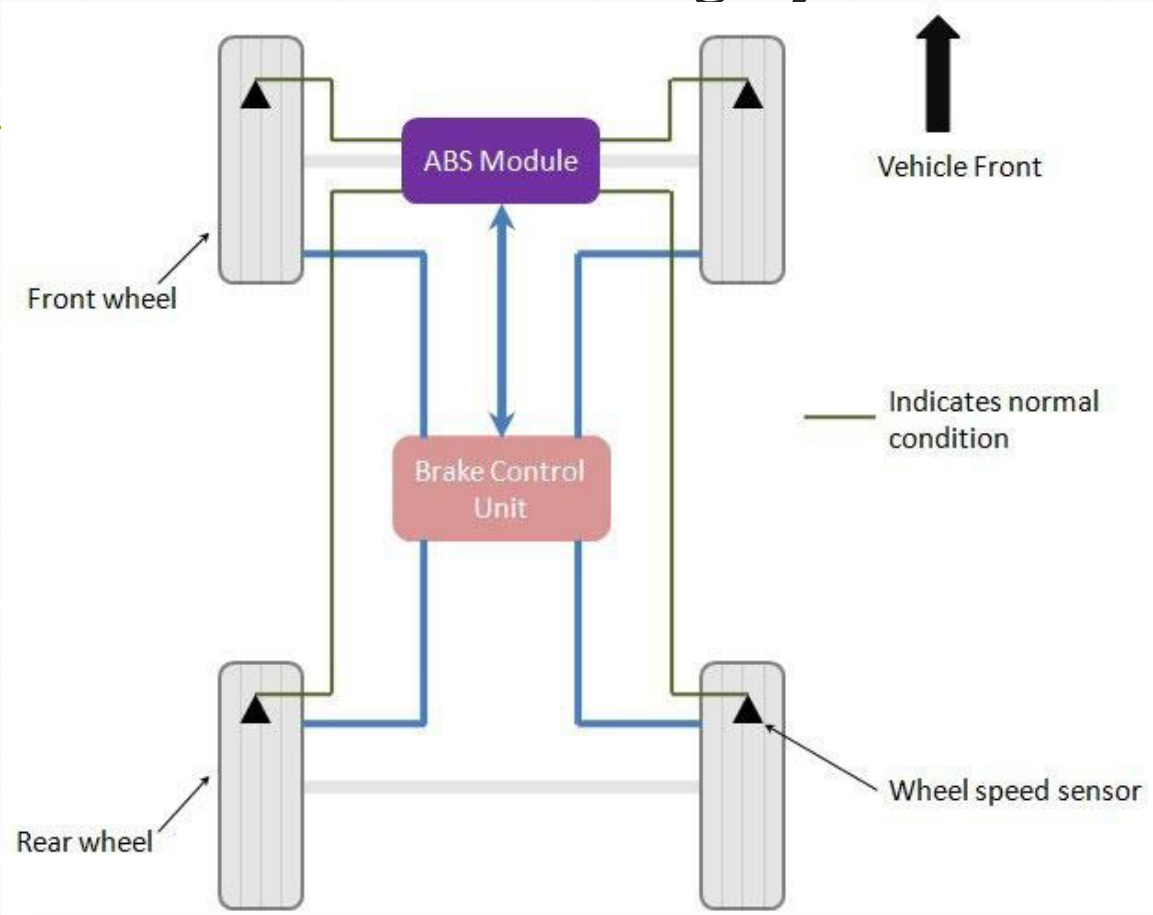

# Types of ABS system

~~Anti-lock braking systems use different schemes depending on the type of brakes in use.~~

They can be differentiated by the number of channels.

1. Four-channel, four-sensor ABS
2. Three-channel, four-sensor ABS
3. Three-channel, three-sensor ABS
4. Two-channel, four-sensor ABS
5. One-channel, one-sensor ABS



## Main Components of ABS system

- Speed Sensors or brake calipers

---

- Pumps or motors
- Valves or channels
- Controller or ECU



ABS Controller

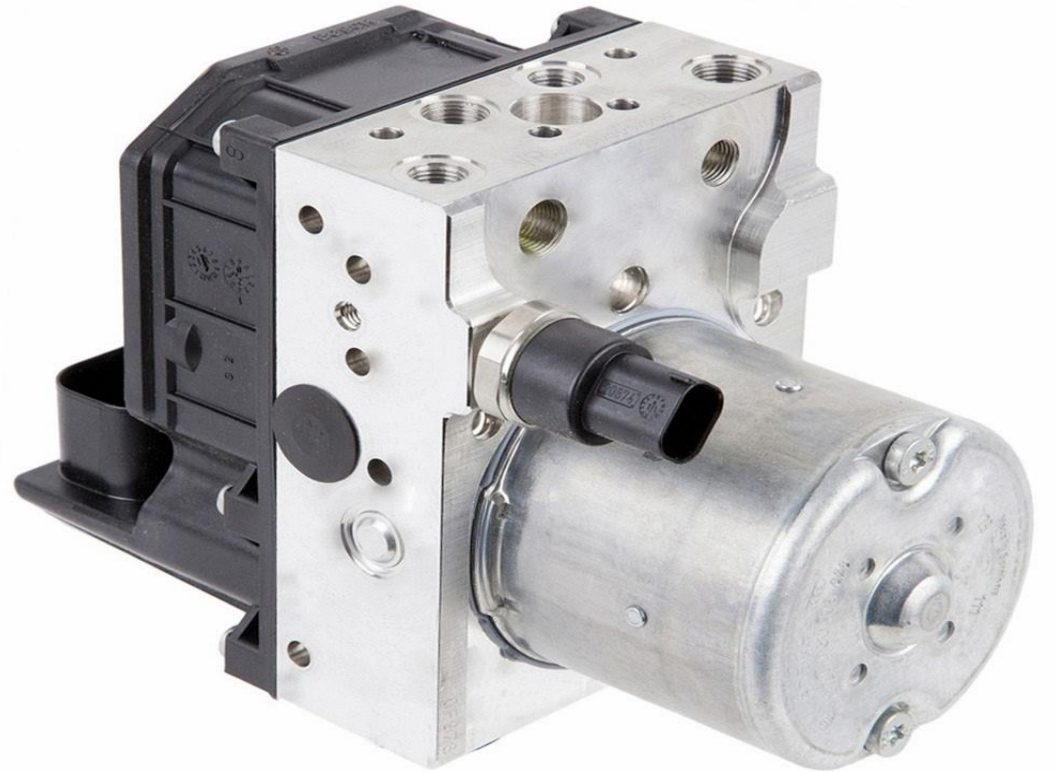

ABS Pump



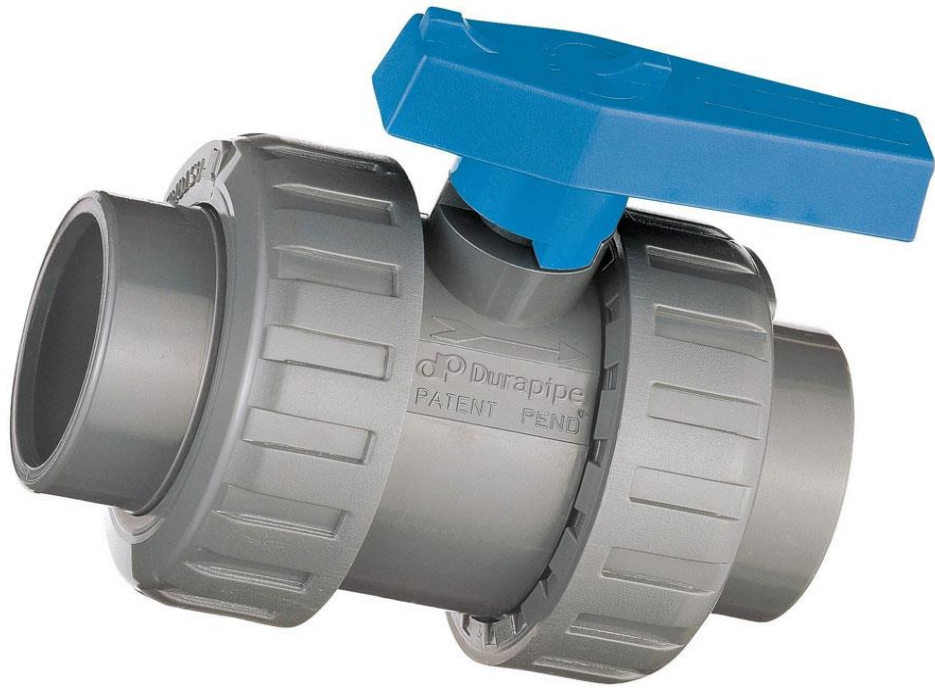

ABS Valve



ABS Sensor

# Anti-lock Braking System

## Antilock braking system

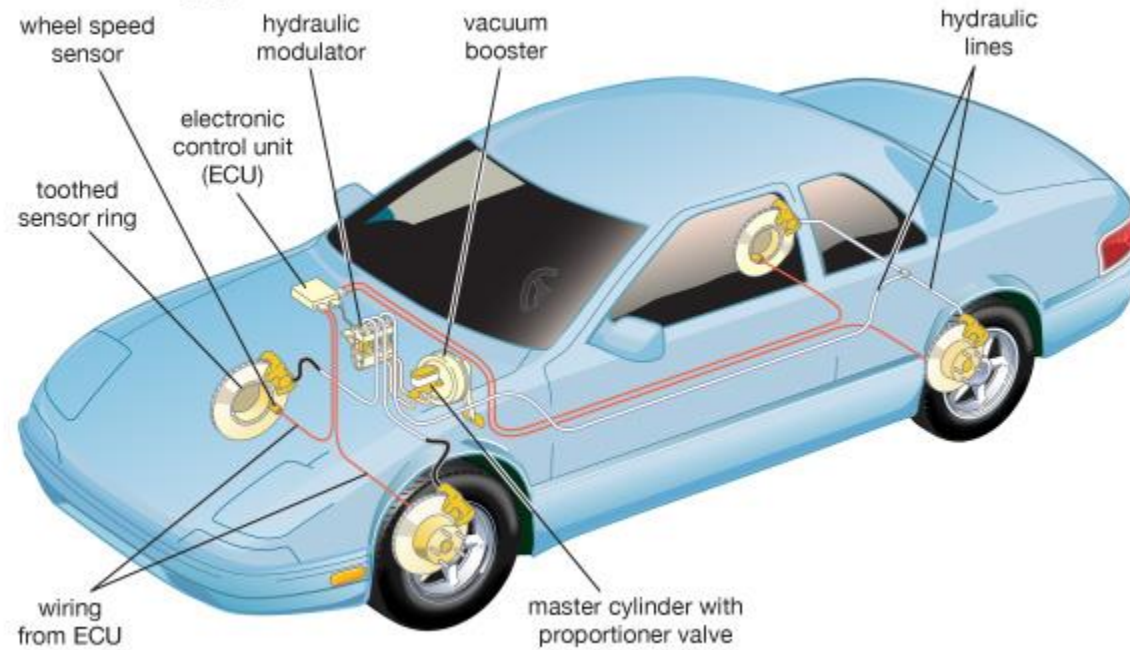



# Theory of ABS system

---

- ABS system works on the principle of threshold braking and cadence braking.
- Cadence braking and threshold braking is a technique in which a driver applies the brakes and releases it before locking up the wheel and then applies the brakes and releases it again before locking.
- This process of applying and releasing the brakes on the wheel is done in pulse form to prevent it from locking and stop skidding of the vehicle.
- The driver practices this technique to achieve better control over the vehicle during instant braking and stop skidding of the vehicle.
- The ABS system automatically does this cadence braking to prevent locking of wheel and skidding of vehicle when brakes are applied.

## Working Principles of ABS system

---

- The four sensors at each of the four wheels sense the rotation of the wheel.
- If the driver gives too much brake application, the wheel stops rotating.
- The wheel sensors reports ECU to release brake line pressure and leads to wheels turning again.
- Then ECU applies pressure again and stops the rotation of the wheel.
- This releasing and re-application or pulsing of brake pressure happens 20-30 times per second or more.



- This keeps the wheel just at the limit before locking up and skidding no matter.
- ABS system can maintain extremely high static pressure and must be disabled ~~before attempting repairs.~~
- When the brake pedal is depressed during driving, the wheel speed decreases and the vehicle speed does as well.
- The decrease in the vehicle speed is not always proportional to the decrease in the wheel speed and the vehicle speed is called “slip”.
- The magnitude of the slip is expressed by the “slip ratio” which is defined as follows:

$$\text{Slip ratio} = (\text{Vehicle speed} - \text{Wheel speed}) / \text{Vehicle speed} \times 100\%$$

## Advantages of ABS system

---

- Greatly reduce the possibility of brake lock up.
- Provide better chance of steering.
- Highly adaptable to every surface.
- Greatly reduces the possibility of vehicle skidding.
- Faster reactions to situations because of completely electronic & computer controlled.



## Disadvantages of ABS system

---

- Expensive repairs & high cost of operation.
- Require regular check ups & maintenance of sensors, valves and brake fluid.
- Require complete overhaul on damage of few parts.
- Delicate system, easy to harm and damage.
- Longer stopping distances due to system errors.

